

## 8MGM25T-1 - Motorized Gimbal Mount *New!*

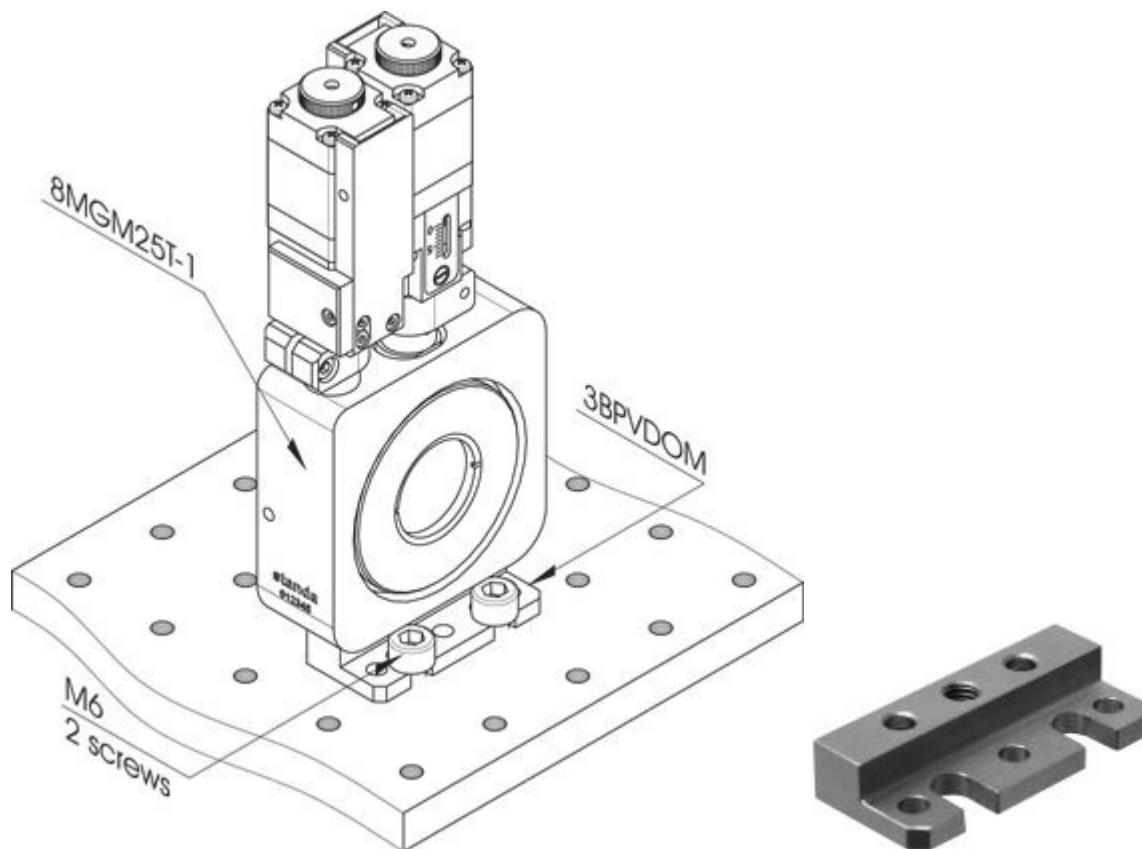

- Angular range  $\pm 2,5^\circ$
- Resolution 0,156  $\mu\text{m}$



Base plate **3BPVDOM** used to fix Mount.

\*Actuator's movement dependence of horizontal position is not linear.

### Specifications

Optics diameter	25,4 mm
Clear aperture	23 mm
Angular range	$\pm 2,5^\circ$
Installed actuators	2 x <b>8CMA20-8/15</b>
Resolution*	

### Models

**Model**  
**8MGM25T-1**

in full step	1,25 $\mu\text{m}$
in 1/8 step	0,156 $\mu\text{m}$
<b>Lead screw pitch</b>	0,25 mm
<b>Repeatability</b>	1 $\mu\text{m}$
<b>Maximum speed</b>	4 mm/s
<b>Cable</b>	1,2 m length cable included
<b>Motor connector</b>	HDB15(M) (wiring diagram)
<b>Weight</b>	0,7 kg
<b>Recommended controllers</b>	8SMC1-USBhF 8SMC3-RS232 8SMC2
<b>Optocoupler end limit switches</b>	2 per actuator
Switch polarity	pushed is open

---

© 2010 STANDA LTD. All rights reserved.

P.O. BOX 377 , 03012 Vilnius, Lithuania; phone: +370 5 2651474; fax: +370 5 2651483; e-mail: [sales@standa.LT](mailto:sales@standa.LT) Motorized Gimbal Mount