

*** READ AND SAVE THESE INSTRUCTIONS ***

MAC 10^â *Original* VE5^â FAN FILTER MODULE INSTALLATION AND SERVICE MANUAL

STANDARD, RSR, RSRE MODELS

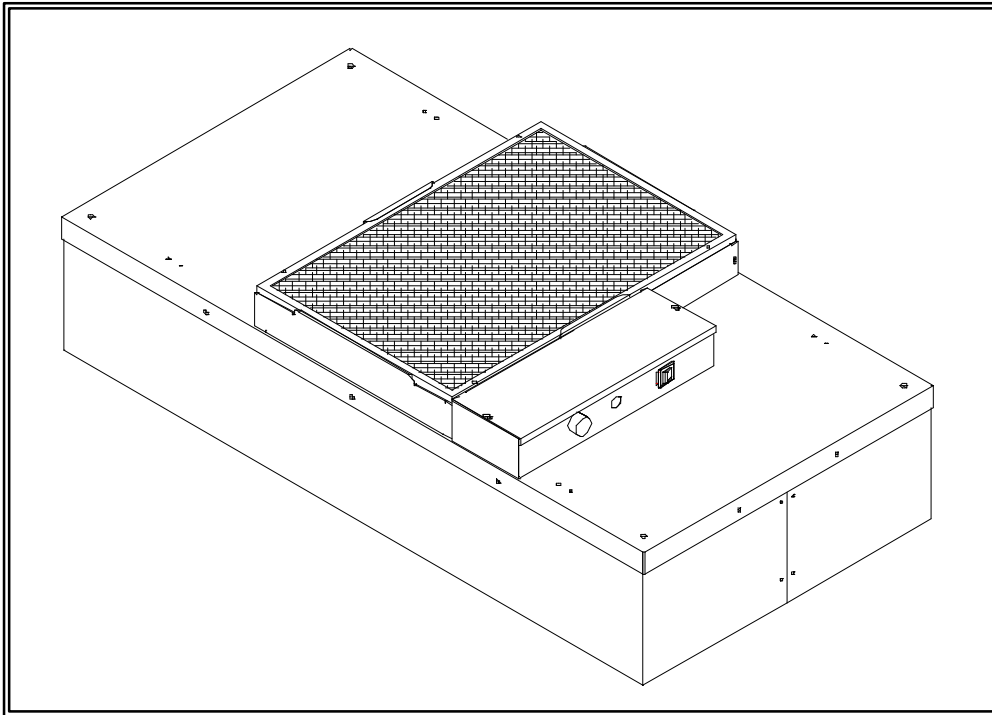

Mac 10^â and VE5^â are registered Trademarks of the
Enviroco Corporation, Albuquerque, New Mexico, U.S.A.

US Patents 4,560,395 and 5,470,363 Other patents issued and pending in foreign countries

Updated 8/06

Critical operation conditions of the MAC 10

1. Touching of the HEPA filter could damage it, voiding the warranty on the filter. The screen is only to protect against an accidental 'touch' of the filter. Never place a hand or tool on the filter. Never lie filter face flat down on a surface always have filter on its side or back to protect from damage.
2. Prior to powering the unit, verify that the unit has been plugged into the correct voltage. The serial number label on the top of the Mac 10 unit has the required voltage.
3. For reorder preprocess the Mac 10 part number and serial number should be recorded. This information is located on the serial number label, located adjacent to the electrical box. If you can't located the Sales Order Number please contact Envirco for this information.

Part Numbers Covered by this Manual

SE11111- 020B	Mac 10 Original 2x4 Standard Filter
11112-XXX	Mac 10 Original 2x3 ½ Standard Filter
11113-XXX	Mac 10 Original 2x3 Standard Filter
11114-XXX	Mac 10 Original 2x2 Standard Filter
11115-XXX	Mac 10 Original 2x4 RSR Filter Sheet Metal Housing
11116-XXX	Mac 10 Original 2x3 ½ RSR Filter Sheet Metal Housing
11117-XXX	Mac 10 Original 2x3 RSR Filter Sheet Metal Housing
11118-XXX	Mac 10 Original 2x2 RSR Filter Sheet Metal Housing
11157-XXX	Mac 10 Original 2x4 RSR Filter Extrusion Housing
11171-XXX	Mac 10 Original 2x3 ½ RSR Filter Extrusion Housing
11169-XXX	Mac 10 Original 2x3 RSR Filter Extrusion Housing
11170-XXX	Mac 10 Original 2x2 RSR Filter Extrusion Housing

Note: A 'Z' in the part number indicates that the unit is special. This may indicate a size change from standard or a special filter. Please contact the factory for part numbers if this is the situation.

READ AND SAVE THESE INSTRUCTIONS

WARNING!

**TO REDUCE THE RISK OF FIRE, ELECTRICAL SHOCK, OR INJURY TO PERSONS,
OBSERVE THE FOLLOWING :**

- A. Installation work and electrical wiring must be done by qualified person(s) in accordance with all applicable codes and standards, including fire-rated construction.
- B. When cutting or drilling into wall or ceiling, do not damage electrical wiring and other hidden utilities.
- C. If this unit is to be installed over a tub or shower, it must be marked as appropriate for the application.
- D. Use this unit only in the manner intended by the manufacturer. If you have any questions, contact the manufacturer:

ENVIRCO CORPORATION

2809E Broadbent Parkway N.E.
Albuquerque, New Mexico 87107, U.S.A.
Tel: (505) 345-3561
Tel: (800) 545-6598
Fax: (505) 345-8875
Email: envirco@envirco.com

ASIAN SALES

No. 205, Lane 218 Zhubo Road
Qingpu District
Shanghai 201700
PRC
Tel: (86) 512 6922 2323
Fax: (86) 512 6922 2283

TRION-ENVIRCO

European Operations
The Cavendish Center Winnall Close
Winchester Hampshire
S023 OLD, UK
Tel: +44 (0) 1962 840465
Fax: +44 (0) 1962 828619

- E. Before servicing or cleaning unit, switch power off at service panel and lock service panel to prevent power from being switched on accidentally.

Table of Contents

Title	Page
1 INSTALLATION.....	5
FIGURE 1 – UNIT UNCRATING.....	5
2 SERVICE: CLEANING THE MAC 10 VE5 PREFILTER.....	6
FIGURE 2 – PREFILTER CLEANING.....	6
3 SERVICE: REMOVAL AND REPLACEMENT OF THE HEPA/ULPA FILTER (STANDARD UNIT).....	7
FIGURE 3 – STANDARD FILTER REPLACEMENT.....	7
4 SERVICE: REMOVAL AND INSTALLATION OF THE ROOM SIDE REPLACEABLE GEL SEAL FILTER – EXTRUSION HOUSING (RSR/RSRE). 8	
FIGURE 4 – RSR EXTRUSION FILTER REPLACEMENT.....	9
5 SERVICE: REMOVAL AND INSTALLATION OF THE ROOM SIDE REPLACEABLE GEL SEAL FILTER – SHEET METAL HOUSING (RSR/RSRE) 10	
FIGURE 5 – RSR SHEET METAL FILTER REPLACEMENT.....	11
6 SERVICE: REMOVAL AND INSTALLATION OF THE MOTOR (STANDARD AND RSR MODELS).....	12
FIGURE 5 – MOTOR REPLACEMENT.....	13
7 SERVICE: REMOVAL AND INSTALLATION OF THE RSRE MOTOR ...	14
FIGURE 6 – RSRE MOTOR REPLACEMENT.....	15
8 ON/OFF SWITCH - SPEED/AIRFLOW ADJUSTMENT.....	16

FIGURE 7 – 3 SPEED SWITCH ADJUSTMENT 16

FIGURE 8 - SPEED CONTROL ADJUSTMENT 16

9 TROUBLE SHOOTING: 17

10 MAC 10 VE5 WIRING DIAGRAMS 18

FIGURE 9 – WIRING DIAGRAM 3- SPEED 18

FIGURE 10 – WIRING DIAGRAM SPEED CONTROL 18

11 MAC 10 VE5 REPLACEMENT PARTS LIST: 19

12 WARRANTY 21

13 TESTING 21

FIGURE 11- VELGRID TESTING 22

1 INSTALLATION

Note: The MAC 10 3- SpeedVE5 Fan Filter Unit is completely assembled at the factory with the exception of the optional ¼" (0.64 cm)-20 eyebolts, which can be used when hanging the unit from an overhead structure.

- Step 1.** Carefully remove the unit from the shipping carton and inspect for any damage that may have occurred during transportation. (See Figure 1)
- Step 2.** Wipe down plastic bag and move unit into clean room. (Double bagging is available upon request.)
- Step 3.** If using rigidly supported grid (usually 2" or wider), raise unit through ceiling and lower onto the gasketed grid. If using a flexible grid (typically supported with wires) the unit must be secured to an overhead structure with eyebolts, s-hooks and chain. A roll of high-density gasket has been provided for use with ungasketed grids. Note: special size units are available to fit specific clean room grid systems.
- Step 4.** Have an electrician wire the unit to the appropriate voltage (115V, 220V, 277V AC), according to the wiring diagram in section IX and local electric codes. If optional power cord was purchased, plug unit into a grounded receptacle.

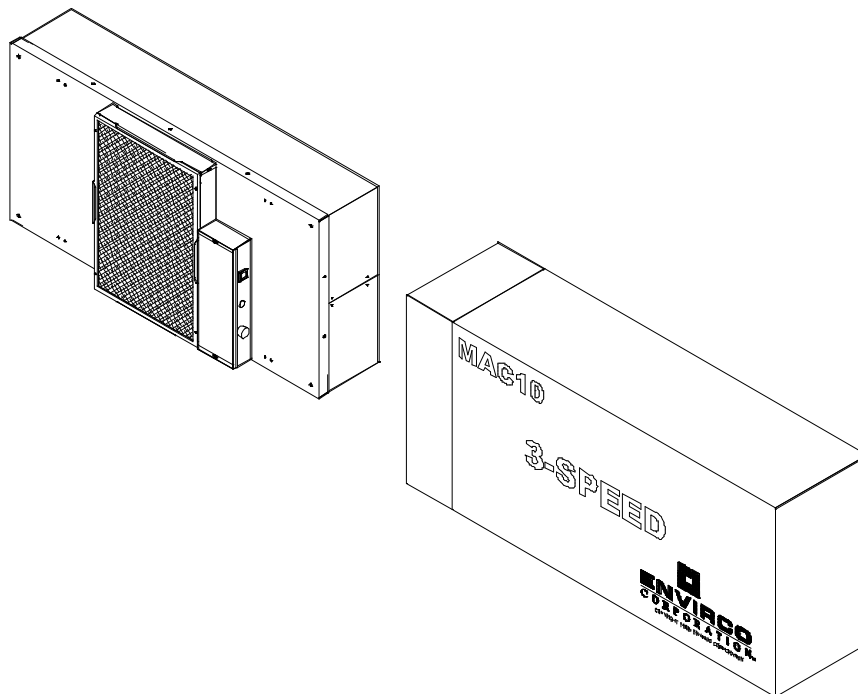

Figure 1 – Unit Uncrating

2 SERVICE: Cleaning the MAC 10 VE5 Prefilter

WARNING!

Disconnect the unit from the electrical power source before attempting any service.

Tools Required: None

Note: To keep the filter in top operating condition, washing the foam prefilter is recommended every three to six months.

- Step 1.** To gain access to the prefilter, remove the ceiling panel next to the unit, if applicable.
- Step 2.** Switch the ON-OFF switch to the off position.
- Step 3.** Remove the prefilter from the snap-in frame. (See Figure 2)
- Step 4.** Clean the prefilter by hand washing in water with a mild detergent or by using a vacuum cleaner. Allow prefilter to dry completely before replacing.
- Step 5.** Reassemble by reversing the above steps.

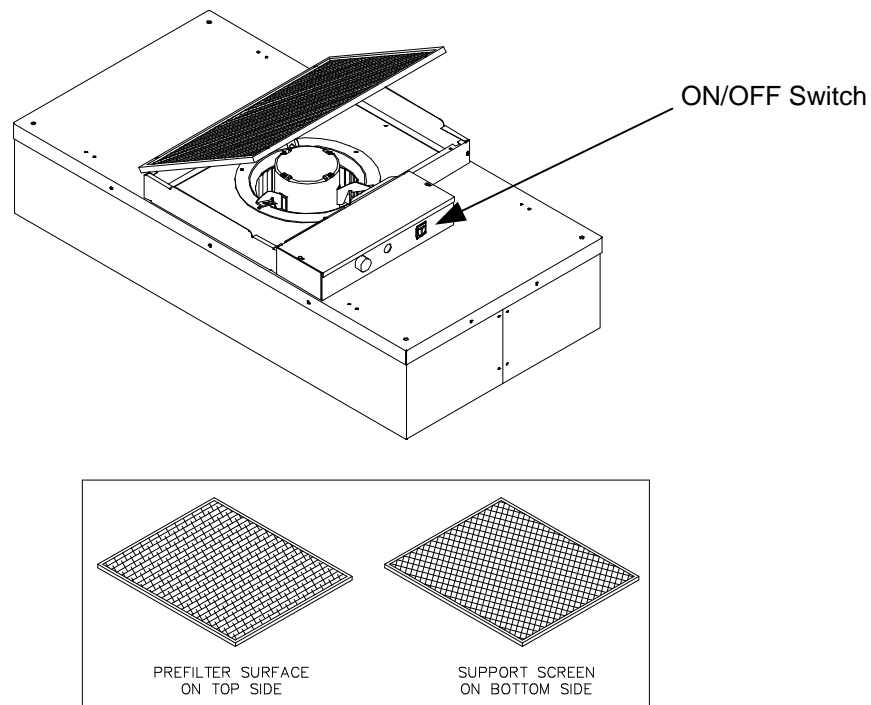

Figure 2 – Prefilter Cleaning

3 SERVICE: Removal and Replacement of the HEPA/ULPA Filter (Standard Unit)

WARNING!

Disconnect the unit from the electrical power source before attempting any service.

WARNING!

The Standard Filter is protected with an expanded metal face screen. This is never to be used to handle the filter. It is only for protection against an accidental touch of the filter. Only handle the filter by the frame.

Tools Required: Phillips Head Driver

Step 1. Remove unit from ceiling.

Step 2. Remove the 10 screws holding the HEPA/ULPA filter to the lid assembly.

Step 3. Lift the lid assembly off the HEPA/ULPA filter (see Figure 3). Discard the used filter as per requirements of the applicable regulations.

Note: Before replacing with a new HEPA/ULPA filter, carefully inspect the new filter for any visible damage. Also inspect the gasket in the “tee” bar to insure a tight seal. Replace as necessary.

Step 4. Replace with the new HEPA/ULPA filter and assemble by reversing the above steps.

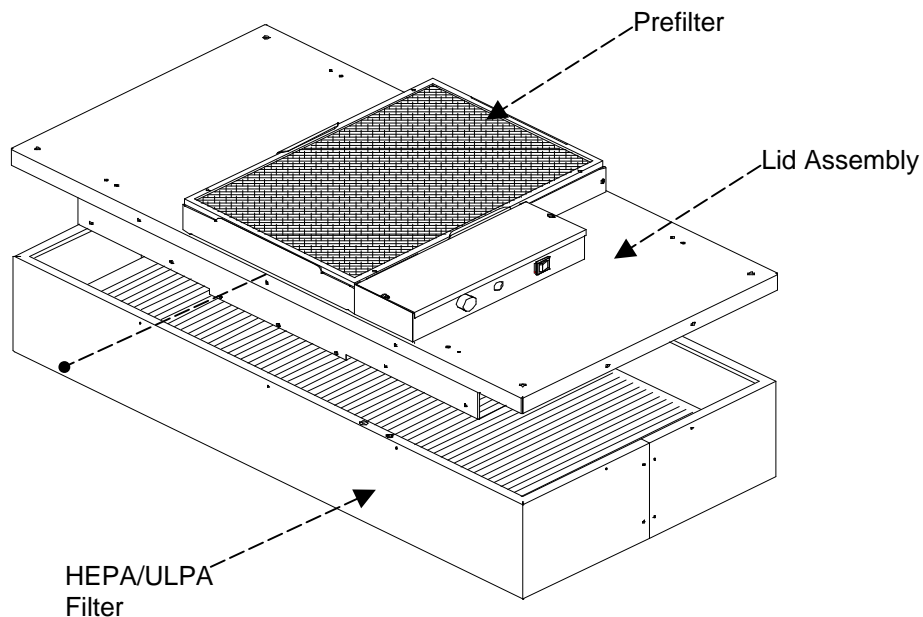

Figure 3 – Standard Filter Replacement

4 SERVICE: Removal and Installation of the Room Side Replaceable Gel Seal Filter – Extrusion Housing (RSR/RSRE)

WARNING!

Disconnect the unit from the electrical power source before attempting any service.

WARNING!

The RSR Filter is protected with an expanded metal face screen. This is never to be used to handle the filter. It is only for protection against an accidental touch of the filter. Only handle the filter by the frame.

Tools Required: 5/32" hex head wrench

Manpower Required: 2

- Step 1.** Remove the diffuser screen by removing the four M5x35 socket head screws securing the screen to the filter. (Figure 4)
- Step 2.** Loosen the six M5x16 socket head screws far enough to rotate the filter clip 180°. The filter will not drop during this operation. Using the clips as handles, slowly pull the filter away from the knife-edge seal. It is important to pull the filter slowly away from the seal, so that the gel remains in the filter gel track.
- Step 3.** Inspect filter for visible damage, if damaged set aside for replacement or repair.
- Step 4.** Inspect the gel seal, if reinstalling the removed filter. Determine if the gel has lost its ability to seal, if so repair the gel.
- Step 5.** Place the filter against the filter-sealing surface of the RSR unit. Install filter clips and screws. The clips can be rotated and angled into place. Using the clips as a lever the filter can be seated. It is recommended to work either clockwise or counter clock wise around the filter, raise the filter into the gel.
- Step 6.** Reinstall screen.

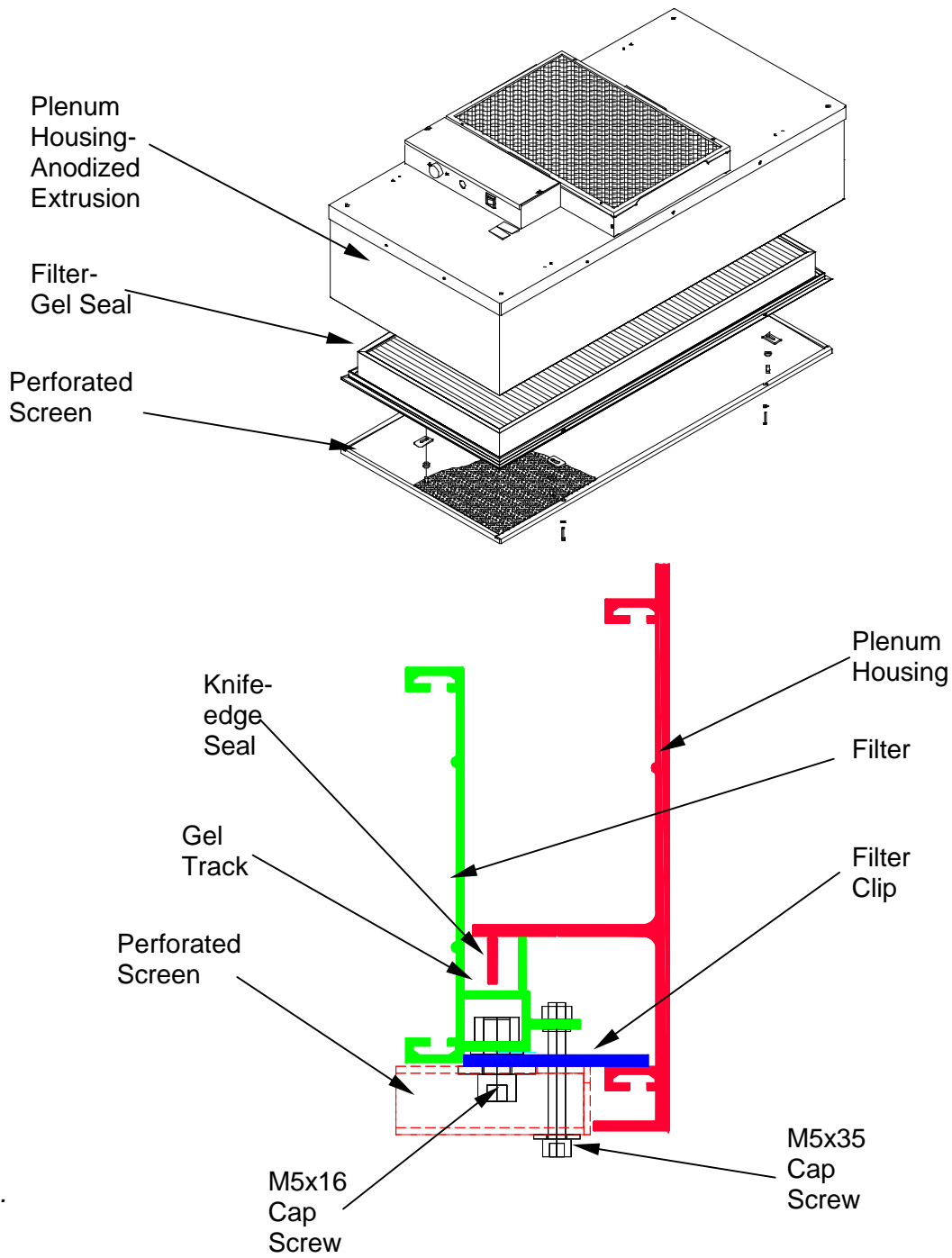

Figure 4 – RSR Extrusion Filter Replacement

5 SERVICE: Removal and Installation of the Room Side Replaceable Gel Seal Filter – Sheet Metal Housing (RSR/RSRE)

WARNING!

Disconnect the unit from the electrical power source before attempting any service.

WARNING!

The RSR Filter is protected with an expanded metal face screen. This is never to be used to handle the filter. It is only for protection against an accidental touch of the filter. Only handle the filter by the frame.

- Step 1.** Remove the diffuser screen by shifting it to one side and lowering it out of the housing.
- Step 2.** Loosen the six M5x16 socket head screws far enough to rotate the filter clip 180°. The filter will not drop during this operation. Using the clips as handles, slowly pull the filter away from the knife-edge seal. It is important to pull the filter slowly away from the seal, so that the gel remains in the filter gel track.
- Step 3.** Inspect filter for visible damage, if damaged set aside for replacement or repair.
- Step 4.** Inspect the gel seal, if reinstalling the removed filter. Determine if the gel has lost its ability to seal, if so repair the gel.
- Step 5.** Place the filter against the filter-sealing surface of the RSR unit. Install filter clips and screws. The clips can be rotated and angled into place. Using the clips as a lever the filter can be seated. It is recommended to work either clockwise or counter clock wise around the filter, raise the filter into the gel.
- Step 6.** Reinstall screen.

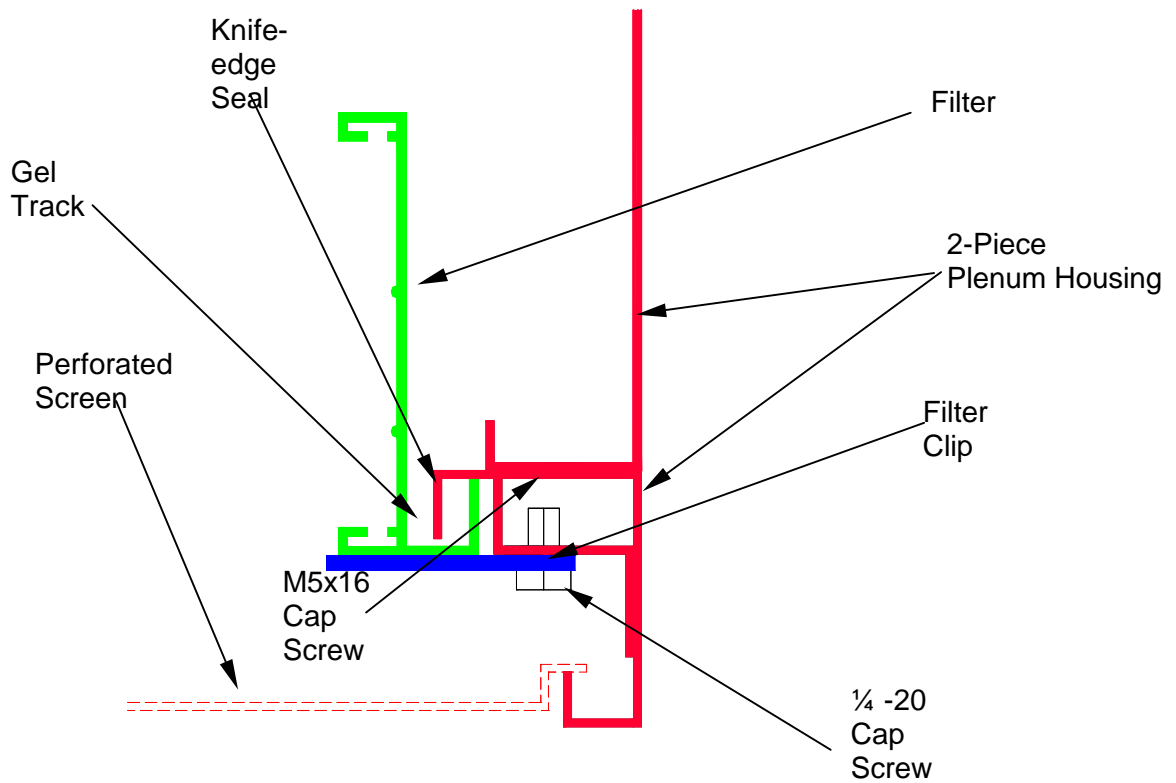
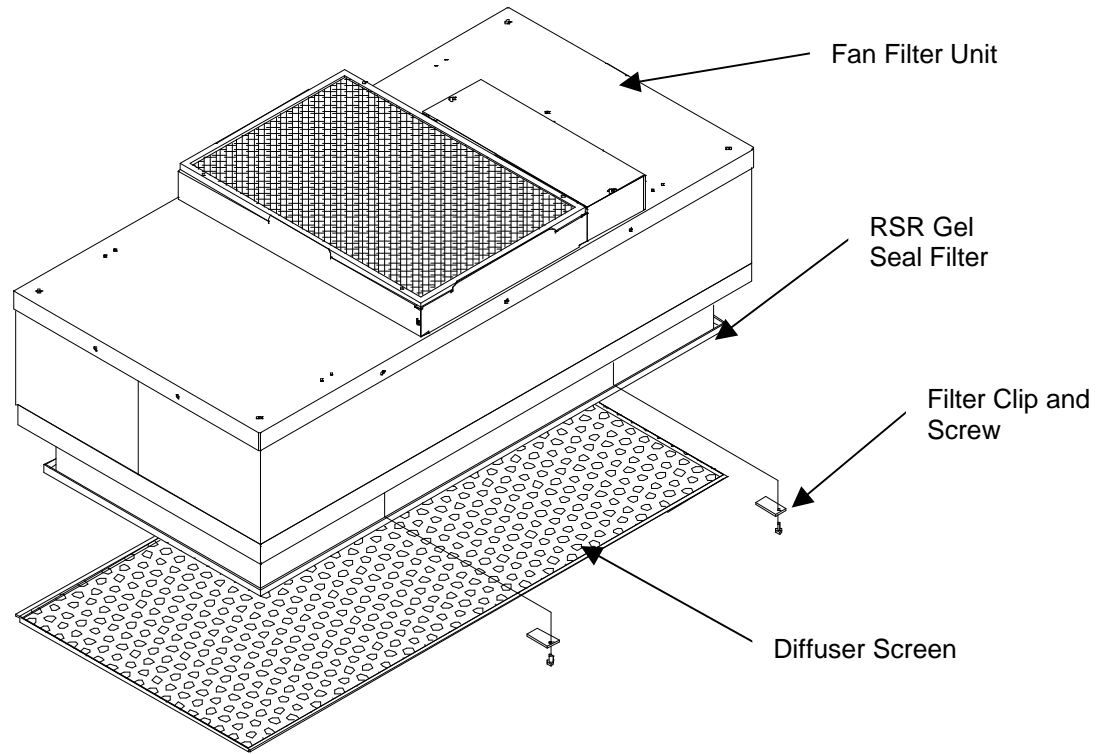

Figure 5 – RSR Sheet Metal Filter Replacement

6 SERVICE: Removal and Installation of the Motor (Standard and RSR models)

WARNING!

Disconnect the unit from the electrical power source before attempting any service.

WARNING!

Electrical service should be performed by licensed electricians or authorized ENVIRCO service technicians.

Tools Required: **Phillips Head Driver**
 3/8" (10mm) Hex Head Wrench
 Pliers
 5/32"(0.40 cm) Allen wrench

- Step 1.** To gain access to the motor, remove the ceiling panel next to the unit, if applicable.
- Step 2.** Switch the ON-OFF switch to the off position.
- Step 3.** Remove the prefilter off the prefilter frame. (See Section II)
- Step 4.** Loosen the electrical box cover screws (2), and slide/lift off cover. (Figure 5)
- Step 5.** Make note of all wire locations for reinstallation later.
- Step 6.** Disconnect the two brown wires from the capacitor, using a pair of pliers.
- Step 7.** Disconnect the motor wiring from the rotary switch and rocker switch or speed control and rocker switch and remove the grommet from the motor leads. Save this grommet for reinstallation.
- Step 8.** Remove the six screws to free the venturi ring and remove the motor/blower assembly from the lid assembly. If using power drivers, set the unit to a low torque setting to avoid stripping the sheet metal screws. (See Figure 6)
- Step 9.** Using a 5/32"(0.40 cm) Allen wrench remove the blower wheel from the motor shaft. Remove motor from the venturi ring using a hex wrench.
- Step 10.** Replace with the new motor and reassemble by reversing the above steps. Set the spacing between the venturi ring and the blower wheel at 0.06"(0.15 cm) clearance.

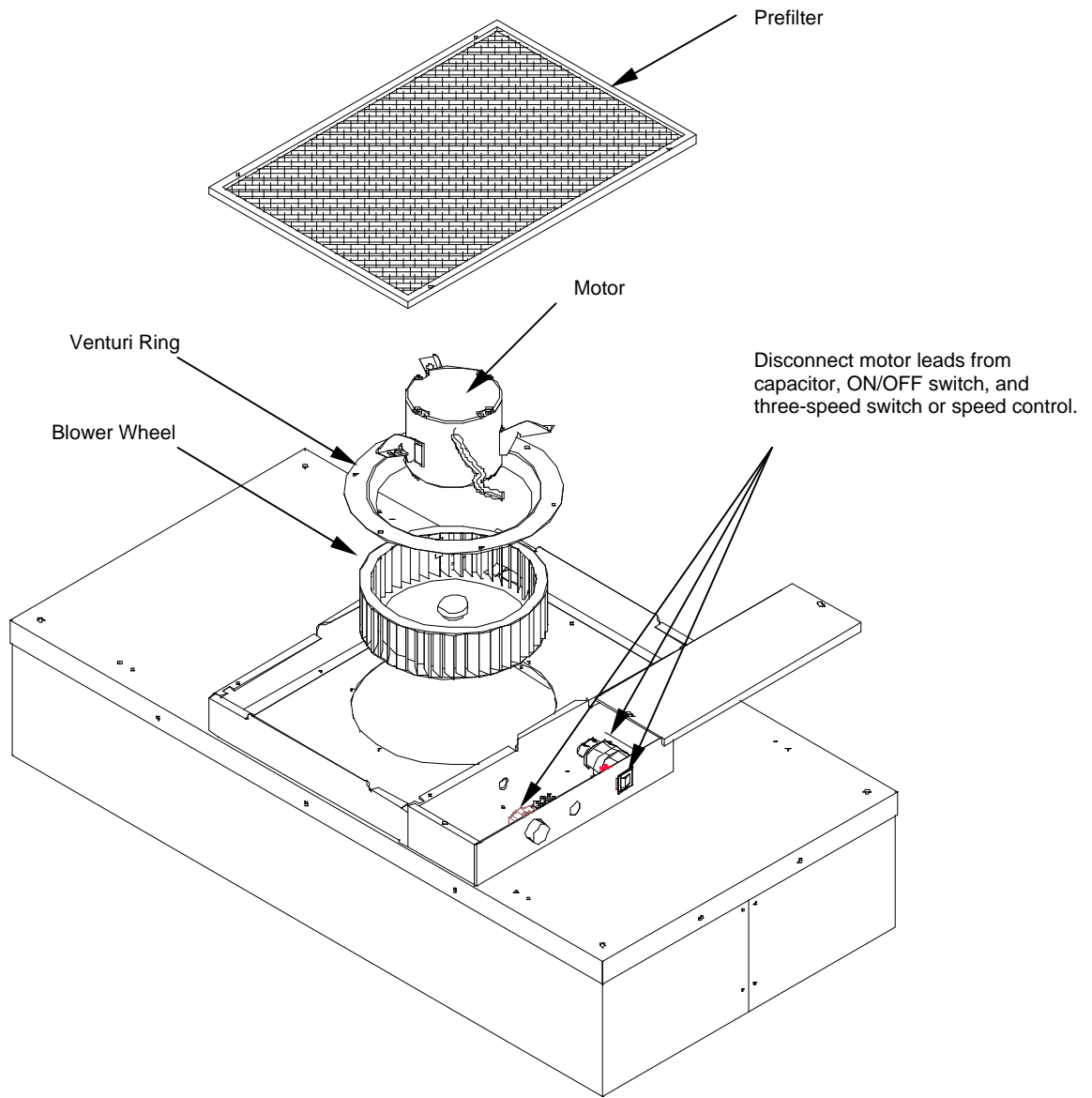

Figure 6 – Motor Replacement

7 SERVICE: Removal and Installation of the RSRE Motor

WARNING!

Disconnect the unit from the electrical power source before attempting any service.

WARNING!

Electrical service should be performed by licensed electricians or authorized ENVIRCO service technicians.

- Step 1.** To gain access to the motor, remove the gel seal filter (see Section III).
- Step 2.** While supporting the baffle assembly from below, remove the four corner screws on the baffle assembly and lower the assembly. (See Figure 7)
- Step 3.** Prior to removing motor/blower assembly, remove electrical box cover (located underneath the lid panel) to expose motor connectors. Disconnect the nine pin connector from it's mate in the prefilter bracket.
- Step 4.** While supporting the motor/blower assembly from below, remove the six machine screws that secure the venturi ring to the bottom face of the lid.
- Step 5.** Using a 5/32"(0.40 cm) Allen wrench, remove the blower wheel from the motor shaft. Remove motor from the venturi ring by removing the three # 10 bolts.
- Step 6.** Before removal of the motor mount bracket, measure the precise location of the bracket on the motor. Remove the bracket.
- Step 7.** Replace with the new motor and reassemble by reversing the above steps. Set the location of the motor mount bracket as measured (see above Step 6). Set the spacing between the venturi ring and the blower wheel at 0.06"(0.15 cm) clearance. When reinstalling the motor plate, align the plate to insure that the leads will reach the electrical box.

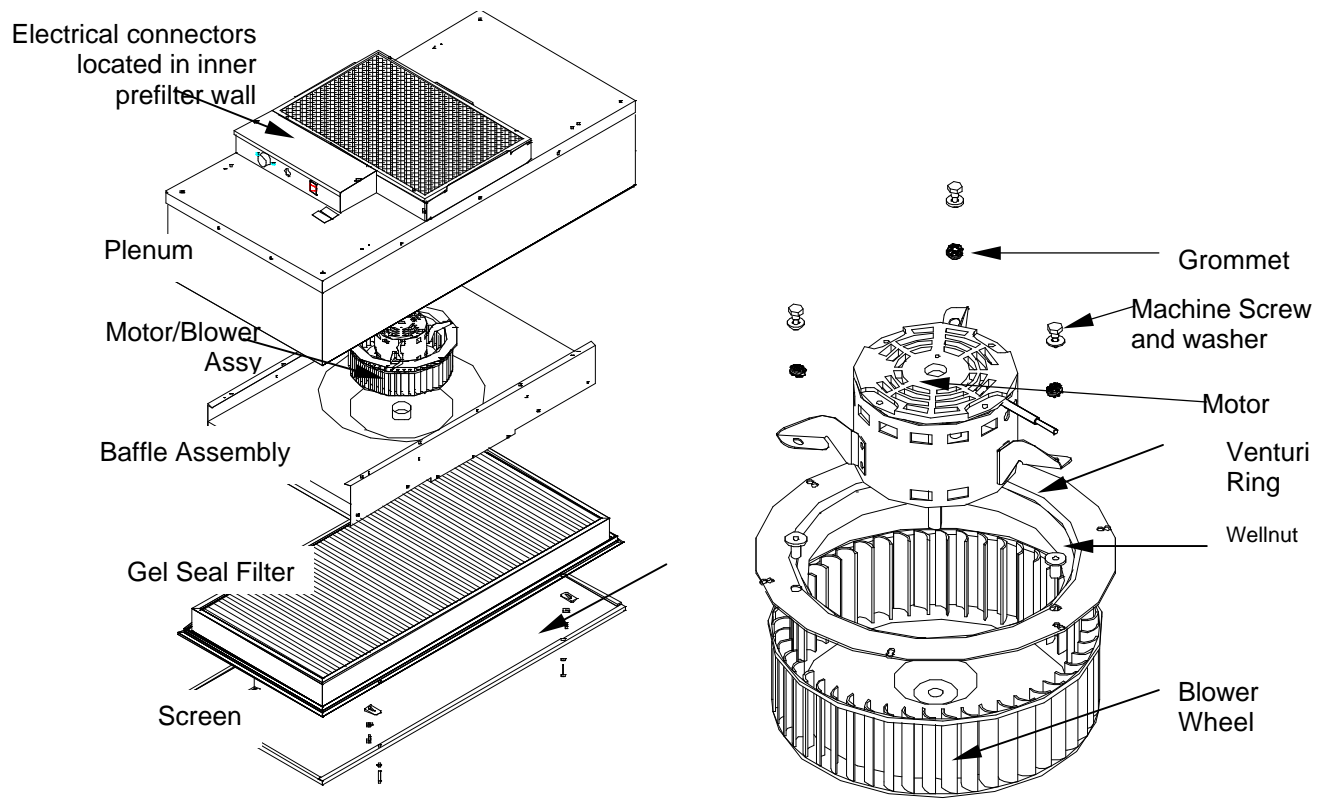

Figure 7 – RSRE Motor Replacement

8 ON/OFF Switch - Speed/Airflow Adjustment

All MAC 10 units are equipped with a three-position rotary switch, which is located on the side of the electrical box. (See Figure 8)

Recommended fan speed during initial start-up and operation is the “LOW” speed. As airflow eventually decreases due to filter loading, fan speed may be increased by moving the rocker switch to the top or “MEDIUM” position, and finally to the “HIGH” position. Periodic airflow velocity readings (Per I.E.S. Specifications) should be conducted to determine the filter condition and appropriate fan speed setting.

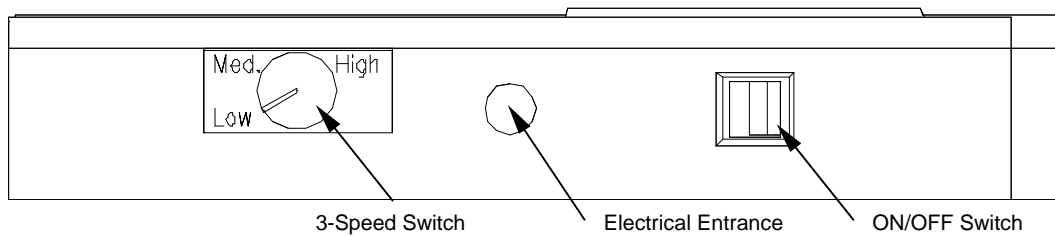

Figure 8 – 3 Speed Switch Adjustment

Optional Speed Control

Units furnished with the optional speed control (the speed control is standard with 2x2 and 2x3 units) enable adjustment of airflow at any setting within the recommended performance range. The speed control knob is located on the side of the electrical box, adjacent to the on/off switch.

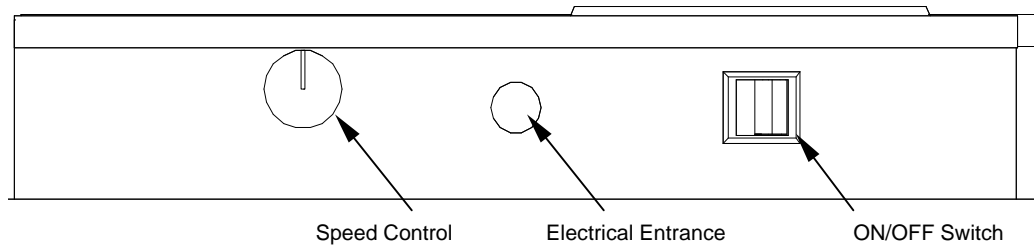

Figure 9 - Speed Control Adjustment

Airflow/speed is adjusted by rotating the knob (See Figure 9):

Clockwise → Lowers the speed

Counter-Clockwise → Increases the speed

Fully rotating the speed control knob to the left or counter-clockwise will turn the unit off.

Note : When turning the unit “ON” from the “OFF” position of the speed control, the fan is at the highest speed. Turning the speed control knob clockwise will lower the airflow.

9 Trouble Shooting:

Low Air Velocity

- Step 1.** Check prefilter media; replace or clean as necessary.
- Step 2.** Flip switch from “Low” to “Medium” or “Medium” to “High” on units with 3-speed switch.
- Step 3.** Adjust variable speed control (only units with *optional* Speed Control) for higher blower output.
- Step 4.** Check power supply for proper voltage, amperage and distribution frequency.
- Step 5.** Replace HEPA/ULPA filter if the air velocity remains low.

High Air Velocity

- Step 1.** Flip switch from “HIGH” to “MEDUIM” to “LOW” on units with 3-speed switch.
- Step 2.** Adjust variable speed control (only units with *optional* Speed Control) for lower blower output.

Non-Laminar Flow and/or Excessive Contamination

- Step 1.** Insure that no large obstructions are upstream of airflow pattern.
- Step 2.** Determine that no other air-moving devices are operating in or around clean room which disrupt room’s airflow pattern.
- Step 3.** Check air velocity and if low, conduct the “Low Air Velocity” procedure outlined above.
- Step 4.** Conduct smoke and photometer test on HEPA filter. Seal or replace HEPA filter as necessary.

10 MAC 10 VE5 Wiring Diagrams

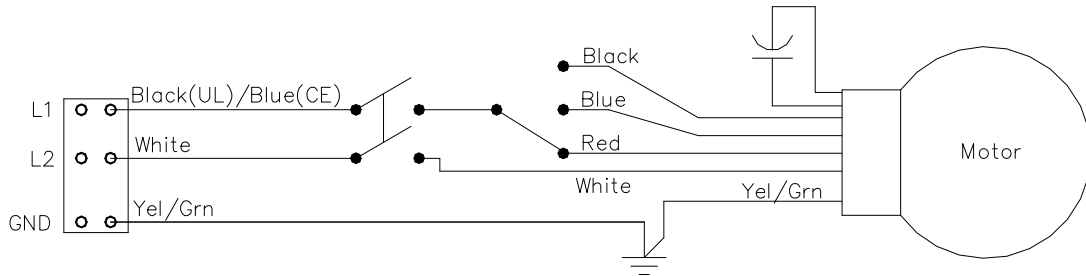

Mac 10 Original Three Speed Wiring Diagram

Figure 10 – Wiring Diagram 3- Speed

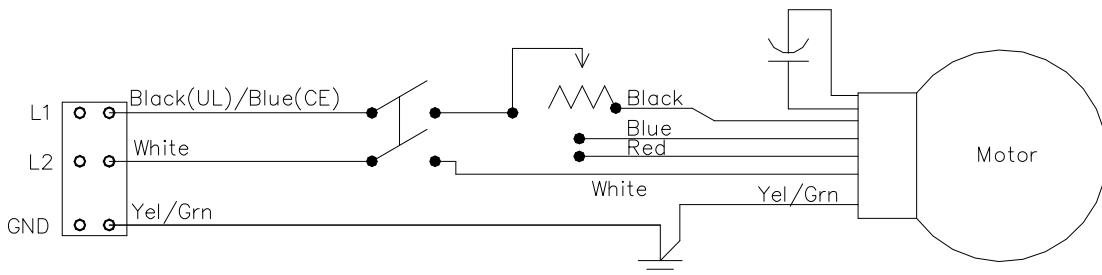

Mac 10 Original Speed Control Wiring Diagram

Figure 11 – Wiring Diagram Speed Control

11 MAC 10 VE5 Replacement Parts List:

Description	Quantity per unit	ENVIRCO Part Number		
		115V	220V	277V
		60 Hz	50 - 60 Hz	60 Hz
Prefilter	1	62981-001	62981-001	62981-001
Motor	1	63764-001	63764-002	63764-003
Capacitor	1	61485	61485	61485
ON/OFF Switch	1	63739	63739	63739
Speed Control (Optional) (CE Marked)	1	63011	63015 63742	63016
Pressure Switch (Optional)		63415	63415	63415
Transformer (Optional)		63667	63666	63665
Current Sensor (Optional)		24235-001	24235-001	24235-001
Power cord (Optional)		63042-001	63042-004	63042-013
Standard Filter: ¹		HEPA	ULPA (Optional)	Actual Filter Dim
2' x 2'	1	69514-004	69514-018	23.63x23.63x9.125
2' x 3'	1	69514-019	69514-012	23.63x35.63x9.125
2' x 3.5'	1	69514-020	69514-021	23.63x41.63x9.125
2' x 4'	1	69514-006	69514-007	23.63x47.63x9.125
RSR Filter – Extrusion Housing: ¹		HEPA	ULPA (Optional)	Actual Filter Dim
2' x 2'	1	69563-005	69563-004	22.00x22.00x3.63
2' x 3'	1	69563-006	69563-007	22.00x34.00x3.63
2' x 3.5'	1	69563-008	69563-009	22.00x40.00x3.63
2' x 4'	1	69563-001	69563-003	22.00x46.00x3.63
RSR Filter – Sheet Metal Housing: ¹		HEPA	ULPA (Optional)	Actual Filter Dim
2' x 2'	1	93997-005	93997-004	21.00x21.00x3.55
2' x 3'	1	93997-006	93997-007	21.00x33.00x3.55
2' x 3.5'	1	93997-008	93997-009	21.00x39.00x3.55
2' x 4'	1	93997-001	93997-003	21.00x45.00x3.55

¹: All filter part numbers are based on the standard Mac 10 sizes (2x4 – 23.63x47.63, 2x3 ½ -23.63x 41.63, 2x3 – 23.63x35.63, and 2x2 – 23.63x23.63). If the unit in question is not this size or the part number includes a “Z” contact the factory for replacement filter information.

Optional Accessories:

Fluorescent lighting

Ionizing bar

Solid-state speed control on 2x4, and 2x3¹/₂ units - (standard on all other sizes)

12"(30.48 cm) diameter A/C intake collar

Gasket Seal Filter (RSR unit only)

ULPA Filter (Standard and RSR)

Replacement parts are available through your authorized ENVIRCO representative. If you cannot locate a representative in your area, contact our Parts Department at:

ENVIRCO CORPORATION

2809E Broadbent Parkway NE

Albuquerque, NM 87107, U.S.A.

Tel: (505) 345-3561

Tel: (800) 545-6598

Fax: (505) 345-8875

12 Warranty

ENVIRCO CORPORATION (“ENVIRCO”) warrants the equipment will be free of defects in materials and workmanship under normal use for a period of three (3) years. The HEPA/ULPA filter shall only be warranted against loading for a period of two (2) years when operated in cleanroom conditions. ENVIRCO’s sole obligation under this warranty is to repair or replace any parts of the equipment which are defective for a period of three (3) years from the invoice date, provided that the repair or replacement is actually performed within the three(3) year period from the invoice date. The buyer agrees to assume any incidental expenses including but not limited to the cost of transporting the defective equipment to ENVIRCO’s repair facility. The buyer’s sole remedy under this limited warranty is the repair or replacement of any defective part of the equipment. ENVIRCO DISCLAIMS ANY IMPLIED WARRANTIES INCLUDING WARRANTIES OF MERCHANTABILITY AND FITNESS FOR A PARTICULAR PURPOSE. In no event shall ENVIRCO be liable for punitive, incidental, or consequential damages arising out of this sale, including, but not limited to damage to persons or property, loss of use, loss of time, inconvenience, equipment rental, loss of earnings or profit or any other commercial loss. This warranty excludes certain expendable items such as light tubes, prefilters, etc. ENVIRCO expressly disclaims and excludes from this warranty any responsibility for equipment failures and/or defects attributable to improper maintenance, abuse, accident or modification of the equipment (such as application of an adjustable frequency drive).

13 TESTING

Each MAC 10 VE5 filter unit is thoroughly tested at the factory before shipment. However, because of the “rigors” of shipping, ENVIRCO encourages its re-test after installation.

ENVIRCO recommends that the customer contact an independent organization, with technicians trained and experienced in performance evaluation and maintenance of clean air equipment.

Some of the testing procedures performed on the MAC 10 VE5 include PSL challenge of HEPA/ULPA filters to assure specified performance, along with air velocity measurement and adjustment tests. No DOP is used on Mac 10 Filters, unless requested.

Recommended Testing

All units that are airflow tested at Envirco are tested using a Shortridge *Airdata Multimeter 800 series* with a Velgrid head. The recommended method of reading is to place one corner of the Velgrid head 1-1/4” from the corner of the filter face and then take four reading evenly spaced along the four foot side, then repeat these reads for the other long side. This gives a total of eight reading to test the unit. All advertised data is based on using the Velgrid with eight

readings (128 velocity points). Envirco recognized using eight reading during a cleanroom start-up may be time consuming and recommends using three Velgrid readings taken on a diagonal, as shown below.

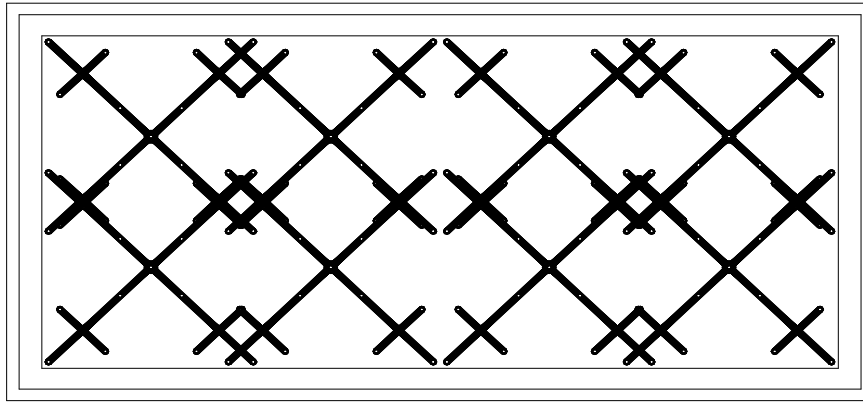

Recommended Testing – 8 readings with a Velgrid

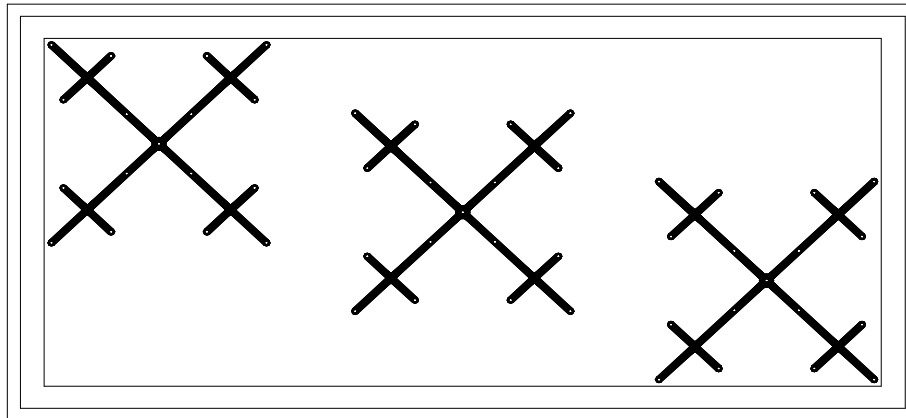

Factory Approved Testing – 3 readings with a Velgrid

Figure 12- Velgrid Testing