

Vibration isolation system

1VIS10W

User manual

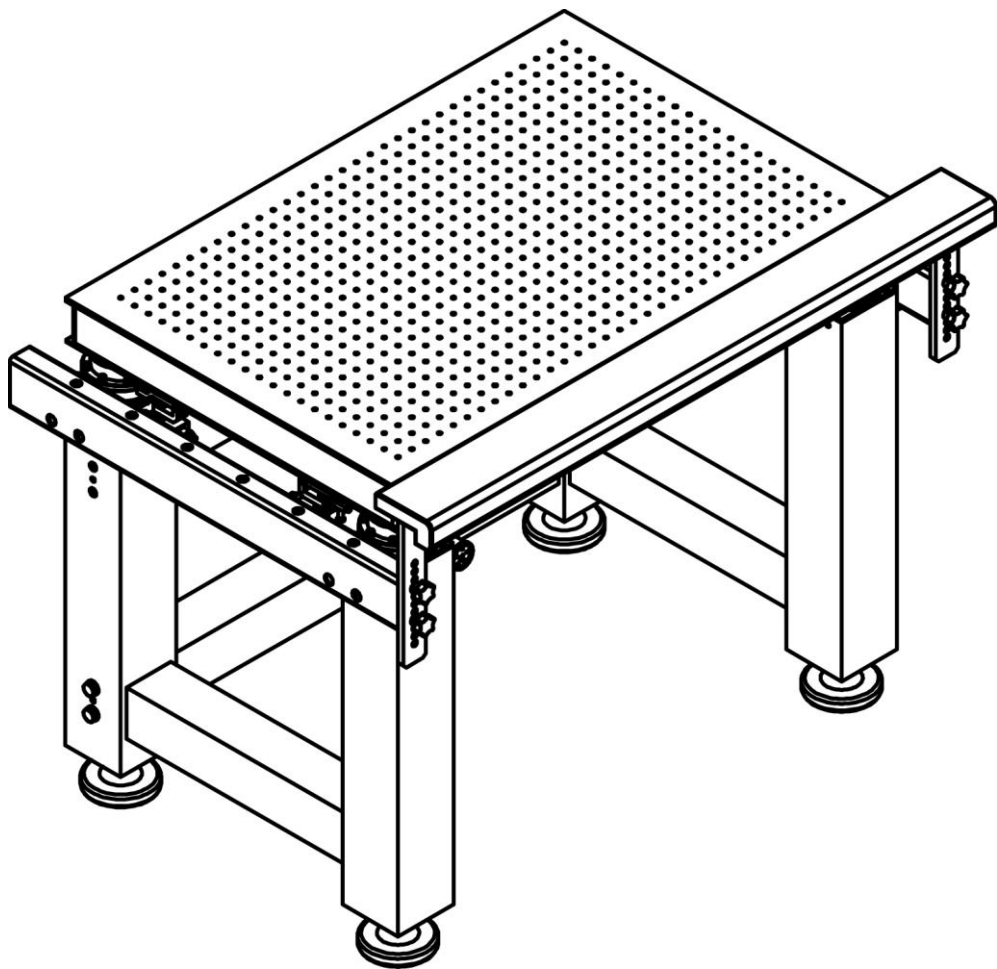

Standa
2014



Table of contents

1. General information	3
1.1. Introduction	3
1.1.1. Safety	5
1.2. Location of the table	5
1.3. Air supply requirements	5
2. Mounting of the system	7
2.1. Assembly of the system	7
2.1.1. Safety	7
2.1.2. Assembly of the frame	7
2.1.3. Connection and installation of pneumatic vibration isolation components	9
2.1.4. Assembly of the support brace	10
2.1.5. Fitting the collector and the support plates	11
2.1.6. Assembly of the table	12
2.2. Preparation of the system for operation and vibration isolation of the table	13
2.2.1. Assembly of level controls	14
2.2.2. Connection of air supply pipes	15
2.2.3. Setting of level controls	16
3. Management of the system	17
3.1. Main principles	17
3.2. Adjustment of parameters of the system	17
3.3. Maintenance	17
3.3.1. Cleaning	17
3.3.2. Air quality	17
4. Installation of Optional Products	18
4.1. Armrest	18

1. General information

1.1 Introduction

The pneumatic vibration isolation system is an ideal work platform for equipment, which is sensitive to vibration, e.g. microscopes, scales, interferometers, and similar devices.

The work surface of the table is separated from the floor by means of a highly effective system of pneumatic supports.

The system features solid and light optical tables of different sizes, which enable the production of a wide selection of systems for a variety of tasks requiring different sizes and loads.

Dimensional drawing of the pneumatic vibration isolation system in Fig. 1.

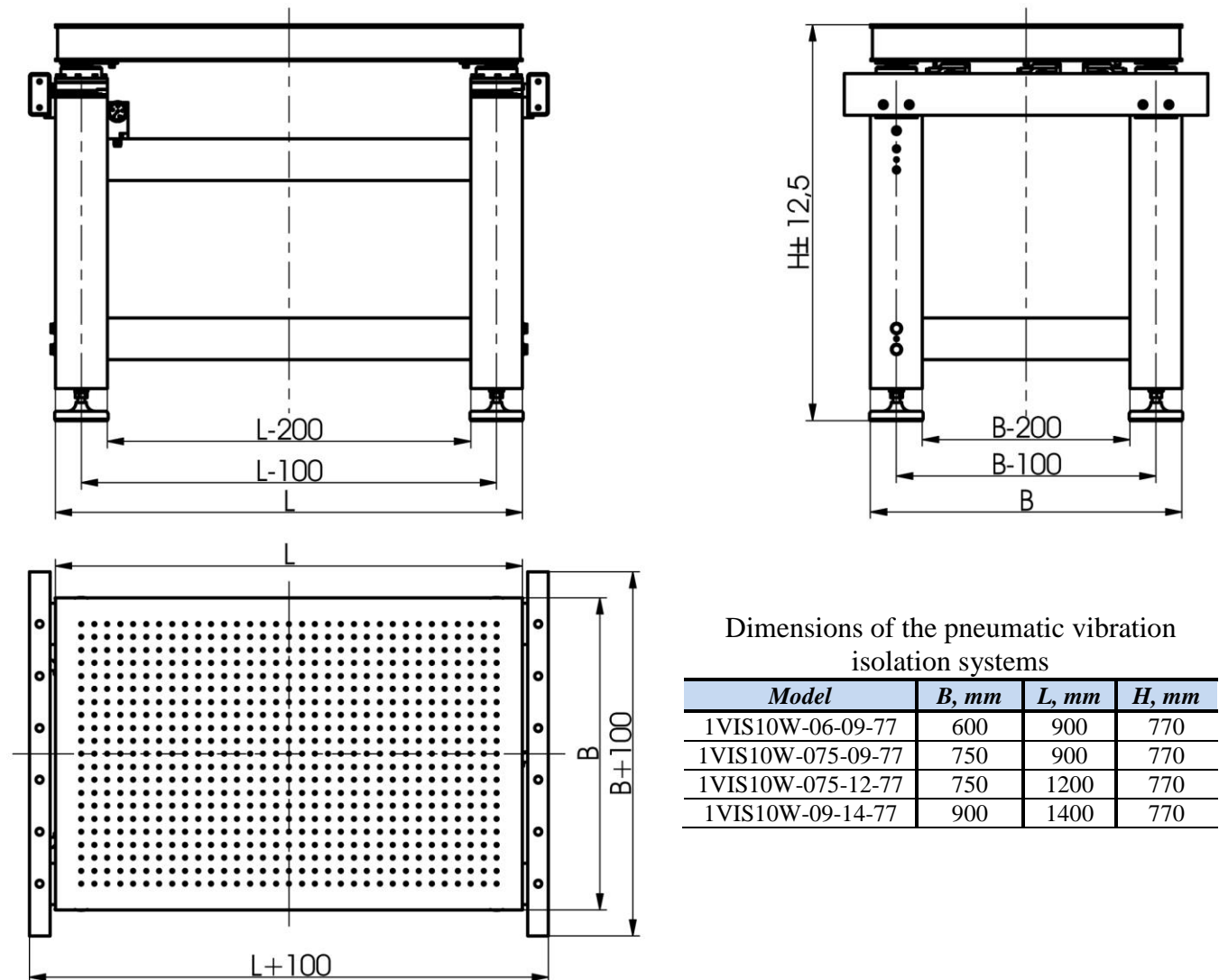

Fig. 1. Dimensional drawing of the pneumatic vibration isolation system 1VIS10W

Specification	Symbol	Value	Unit
Vertical movement range	l_z	14	mm
Precision of automatic level control	Δl_z	± 0.3	mm
Pressure from source of air	p	600 (6 bar) (87 PSI)	kPa
Air supply opening	\varnothing	6	mm
Operating humidity (max)	φ	90 %	%
Operating temperature range	T	10 - 50	°C
Load-bearing capacity (at 6 bar) per isolator	Q	160	kg

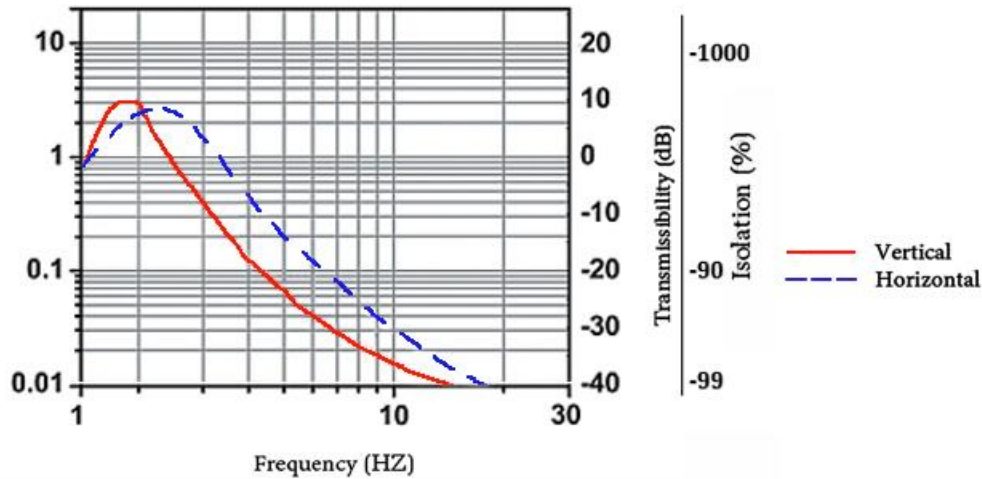

Fig. 2. Specification of 1VIS10W

A specification of a pneumatic support is presented in fig. 2.

Although each support is intended for a load of up to 160 kg, you should prevent overloads of the table at the edges, otherwise any one pneumatic support may become overloaded even if the total weight fits within the limits set. Loads with the centre of gravity located very high may result in instability of the entire system. Please refer to section 3.2 of the manual.

The system is managed by means of level controls; there are 3 controls per system. Please see fig. 3 and fig. 4.

1. Precision of level setting: ± 0.3 mm.
2. Materials:
 Body and lever: anodised aluminium, brass, steel, plastic.

A typical vibration isolation system is shown in fig. 4.

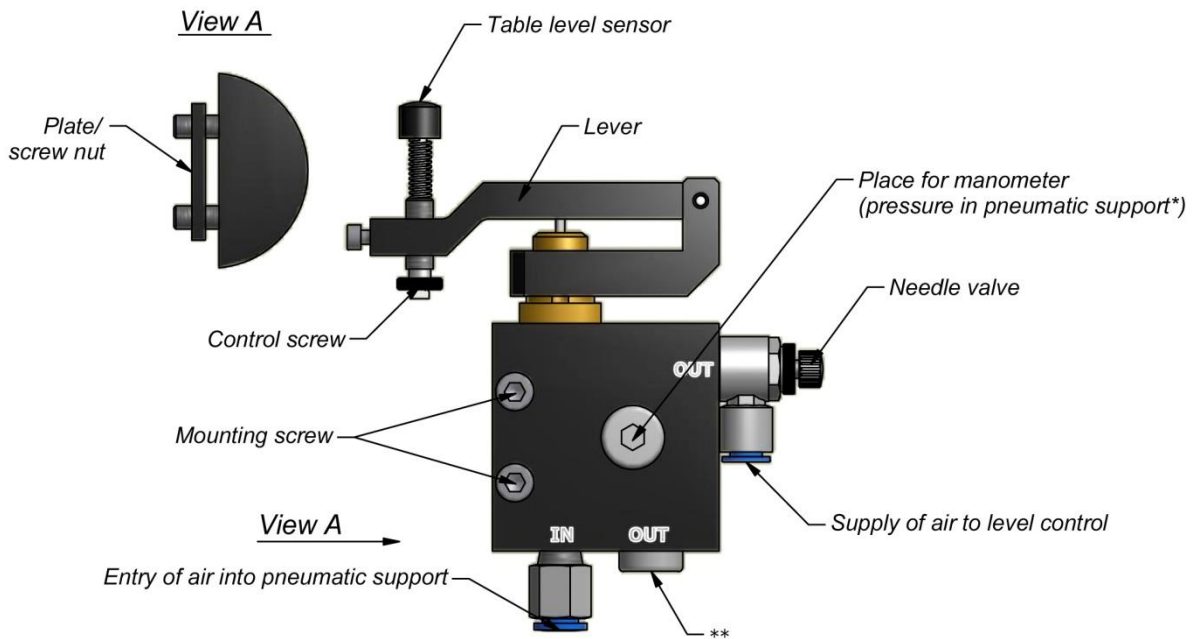

Fig. 3. Level control, model 1LV-1WM

* Optional.

** An overpressure relief valve can be provided.

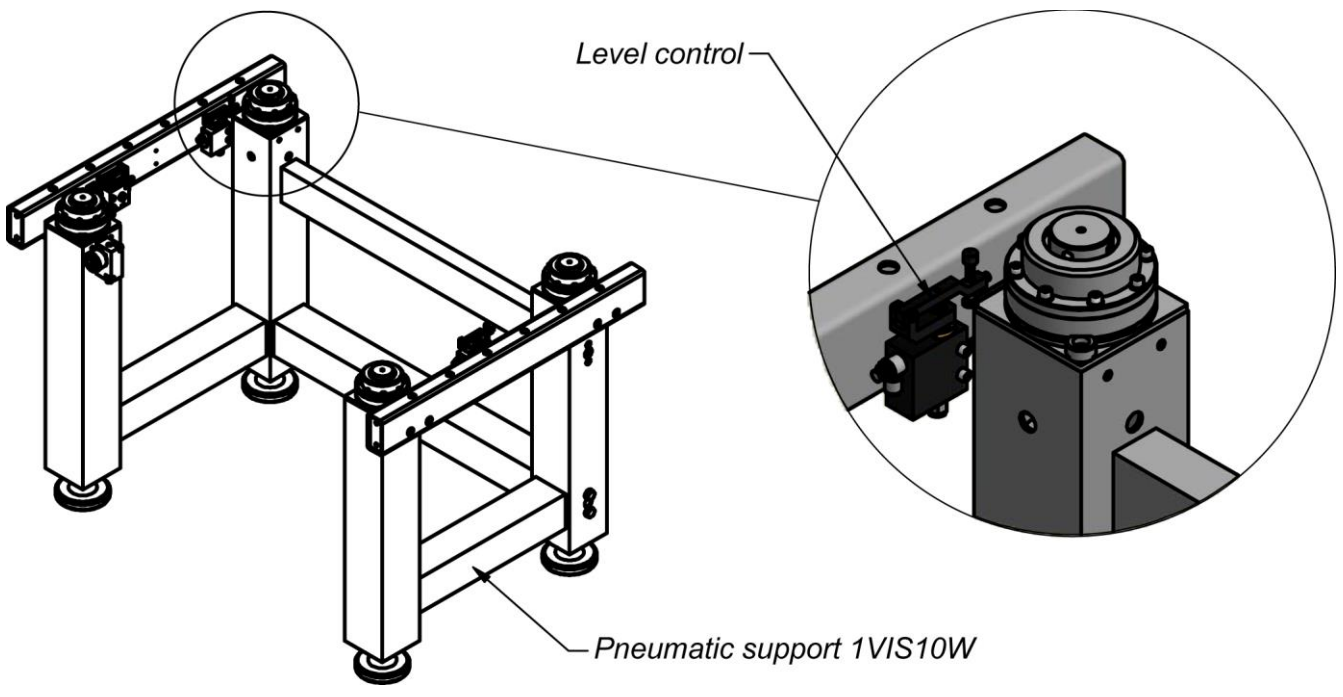

Fig. 4. A typical vibration isolation system



1.1.1 Safety

This manual uses certain terms that are important for your safety.

Warning

Used to denote a danger that may result in injury.



Attention

Used to denote a situation that may result in damage to components of the system.



1.2 Location of the table

To ensure optimal operation of the system, it must be installed on a surface that satisfies certain requirements.

The surface must be even.

It is important that an appropriate location for the system is chosen. The system must be installed in the vicinity of bearing walls or columns, where the impact of low-frequency oscillation is smaller. Furthermore, it is advisable to avoid placing the system in the vicinity of other sources of vibration such as elevators, ventilation systems, industrial equipment, and airflows.

Warning

The system is a metal-made current conductor. If used together with electrical devices, the table must be earthed.



1.3 Air supply requirements

The operation of the system requires a constant supply of air. After the system has been filled in and set, air is used only for the operation of level controls when the load on the table changes.

Compressed air tanks (receivers) may be used for keeping the system operative.

The air supply should be clean and dry for the best long-term results. The filtering degree must be at least 10 µm. The filter prevents impurities and water from entering the level controls, thus preventing them from clogging.

The working pressure of the system is **from 0.5 bar to 6 bar**. The required minimum working pressure for the support with the maximum load may be computed using the following formula:

$$P = \frac{Q}{28.27} + 0.5$$

Where:

P means the required pressure in atm (bar).

Q means the load on the support with the maximum load including weight of the table top (kg).

Example:

Q = 100 kg

$$P = \frac{100}{28.27} + 0.5 = 4 \text{ bar}$$

The air supply system must be provided with a valve (plug) for a complete stoppage of air supply in the case of maintenance and/or resetting of the system, or in cases of major changes in loads of the system.

Attention 
It is not advisable to use compressed carbon dioxide (CO₂) tanks because rapid filling of pneumatic supports may result in their icing up.

2. Mounting of the system

2.1 Assembly of the system

2.1.1 Safety

The weight of the optical table could reach 100 kg. For this reason, to prevent injuries during assembly of the system, lifting mechanisms (a loader) and technological supports must be prepared in advance.

2.1.2 Assembly of the frame 1VIS10WXX-XX-XX (without wheels)

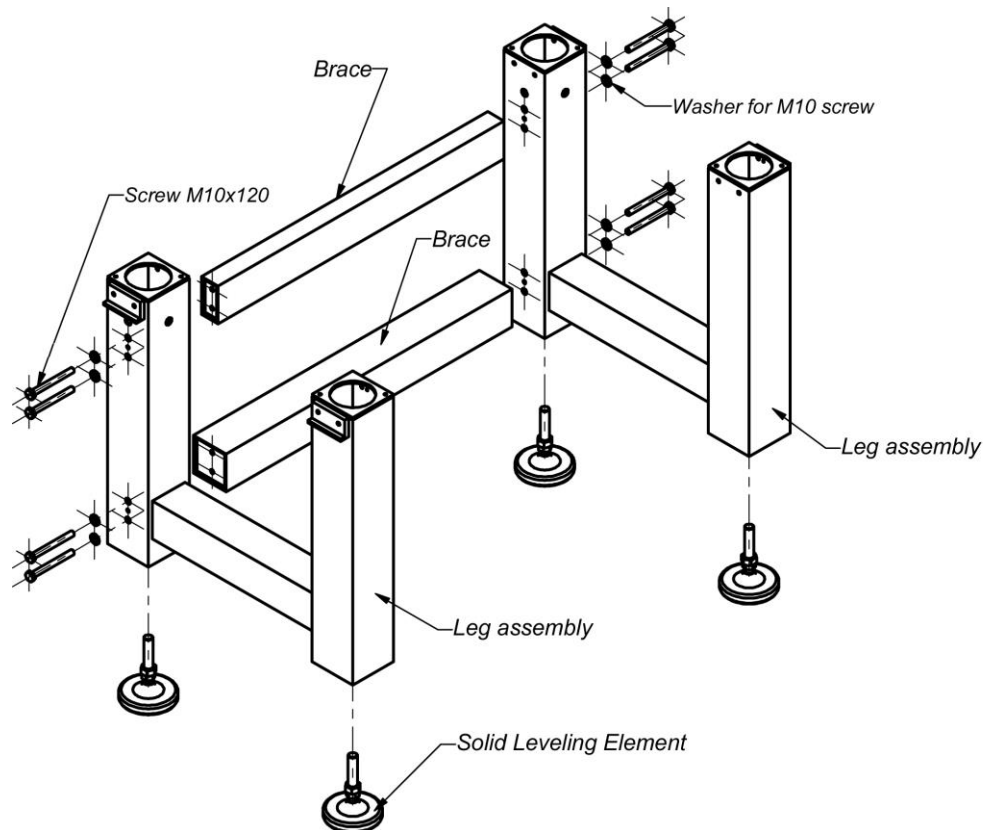

Fig. 5.1 Assembly of the frame

Assembly of the frame is shown in fig. 5.1
 Attach the brace into the leg assembly by M10x120 screws through the washers.
 Screw the solid leveling elements into the leg assembly.

Assembly of the frame 1VIS10WXX-XX-XX-CA (with wheels)

Assembly of the frame is shown in fig. 5.2
 Attach the brace into the leg assembly by M10x120 screws through the washers.
 Screw the solid leveling elements and wheels into the leg assembly.

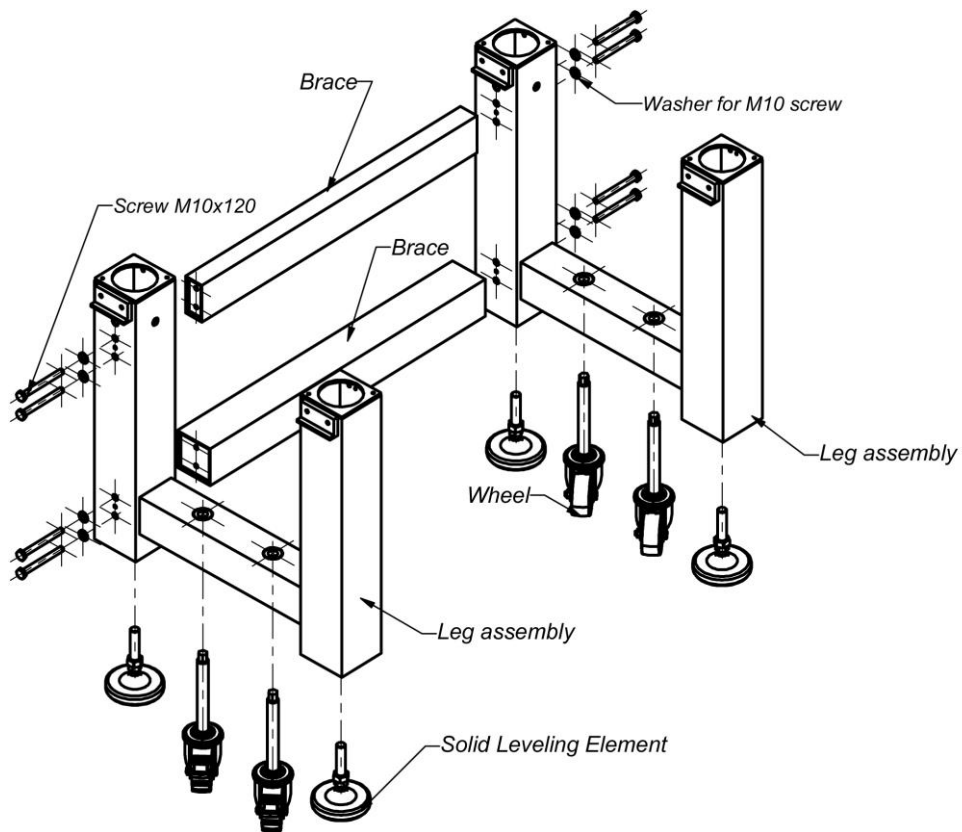
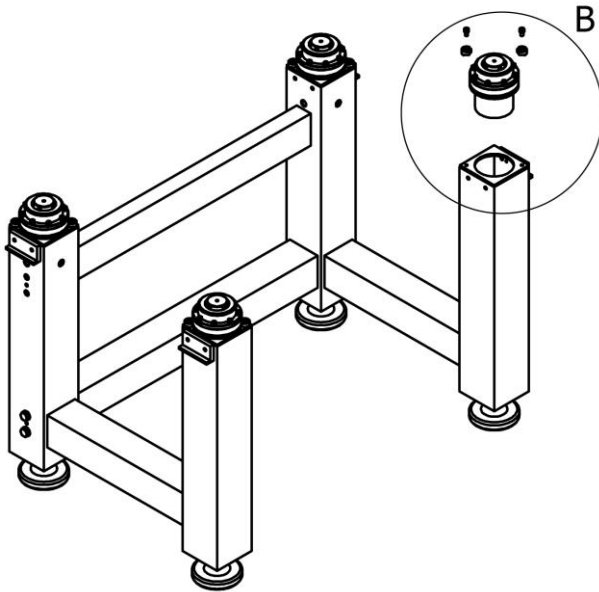

Fig. 5.2 Assembly of the frame

2.1.3 Connection and installation of pneumatic vibration isolation components



Insert the pipes, through the hole for air supply pipe, into the collet fittings until tight. Pull the pipes accurately to make sure that the connection is secure.

The length of the pipes between the fittings must be optimal with a small extra length.

Warning

Cut the edges of the pipes using a sharp cutter at a straight angle. It is not advisable to use scissors because deformation of the pipe edges may lead to leaks from the system.

Attach the pneumo isolation element to the leg assembly by M6x10 screws through the clamps.

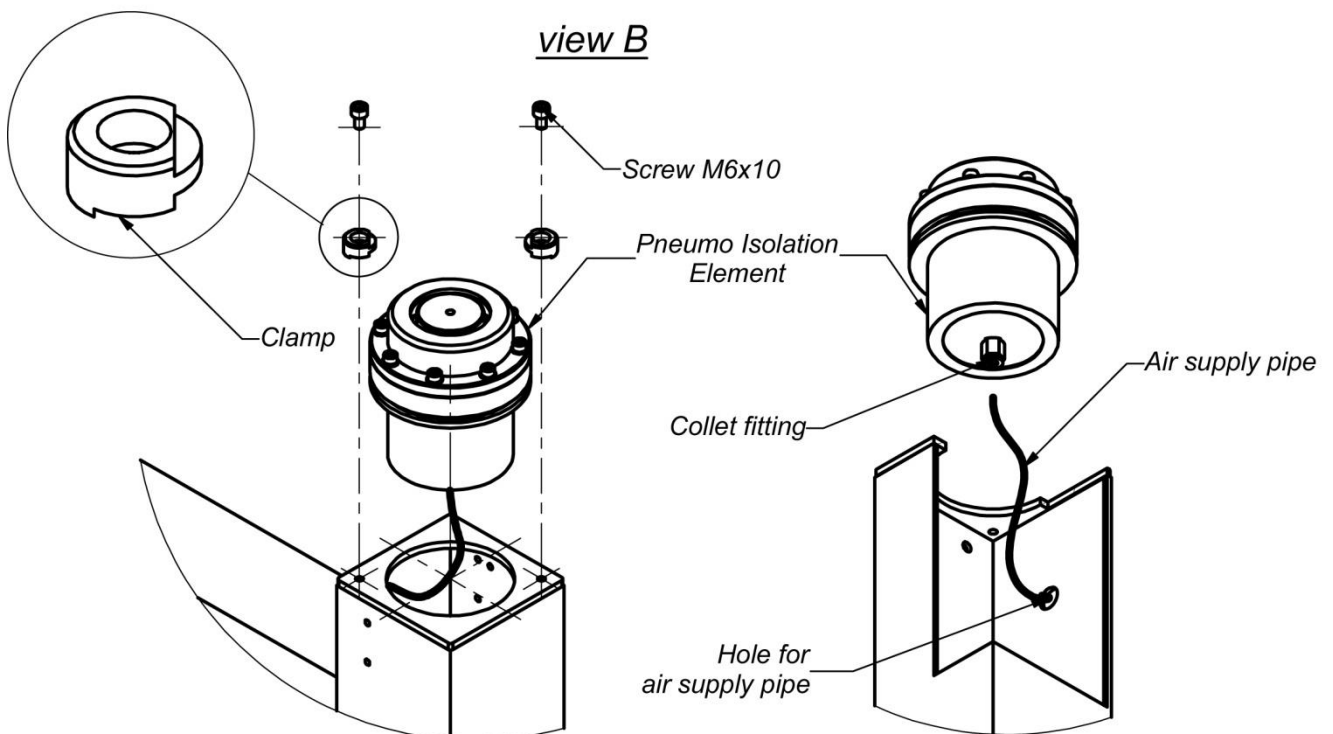
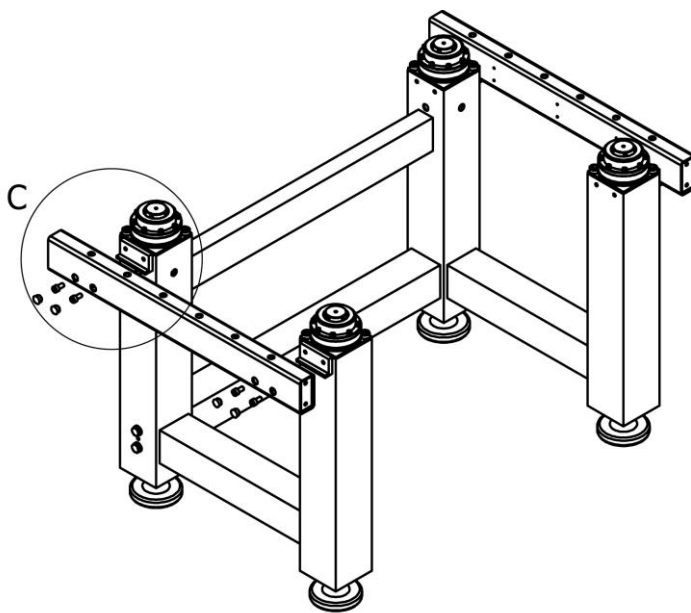

Fig. 6. Connection and installation of pneumatic vibration isolation components

2.1.4. Assembly of the support brace



Attach the support brace to the leg assembly by M8x16 screws.

Insert the plastic caps into the holes.

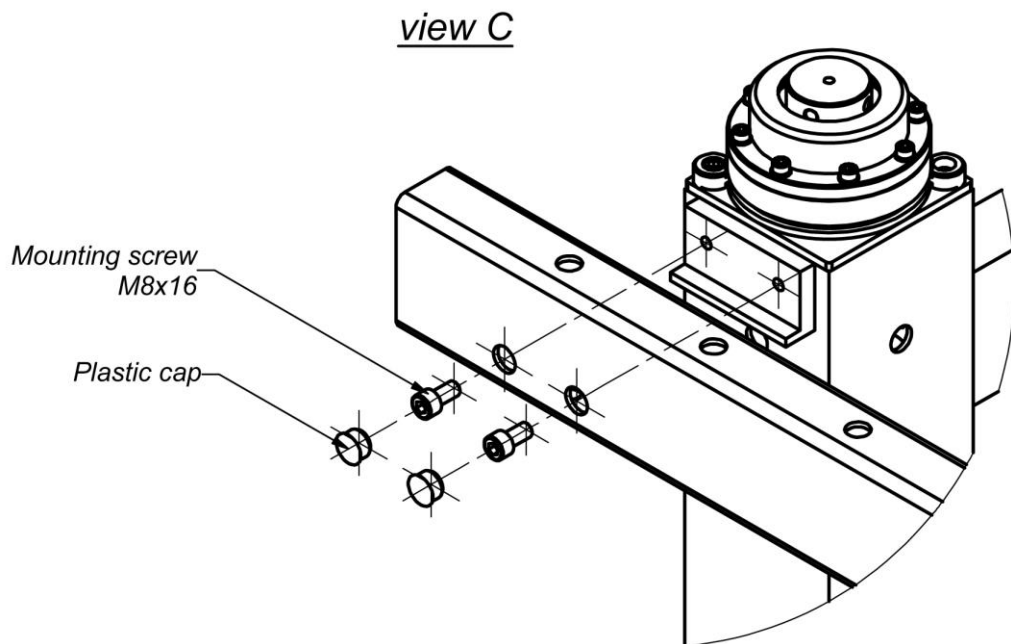
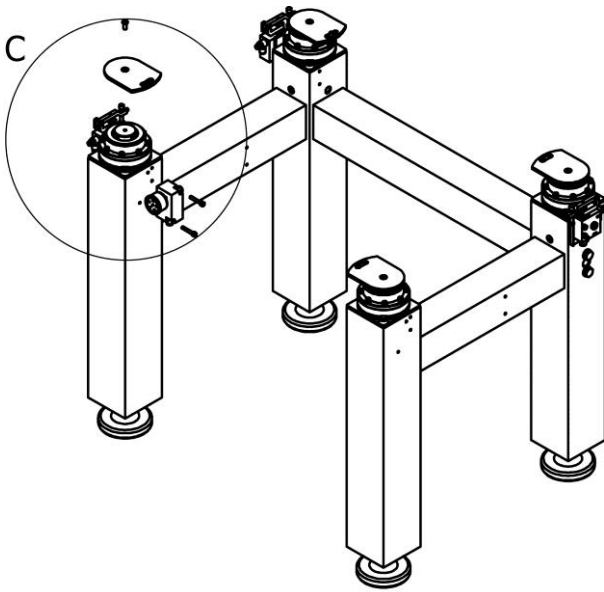

Fig. 7. Assembly of the support brace

2.1.5 Fitting the collector and support plates



Attach the collector to the leg assembly by M5x30 screws.

Insert the hex key 3HK-5 into the hole of the piston and hold it, so that the torque moment doesn't transmit to the diaphragm.

Attach the support plate to the piston by M6x16 screw.

view D

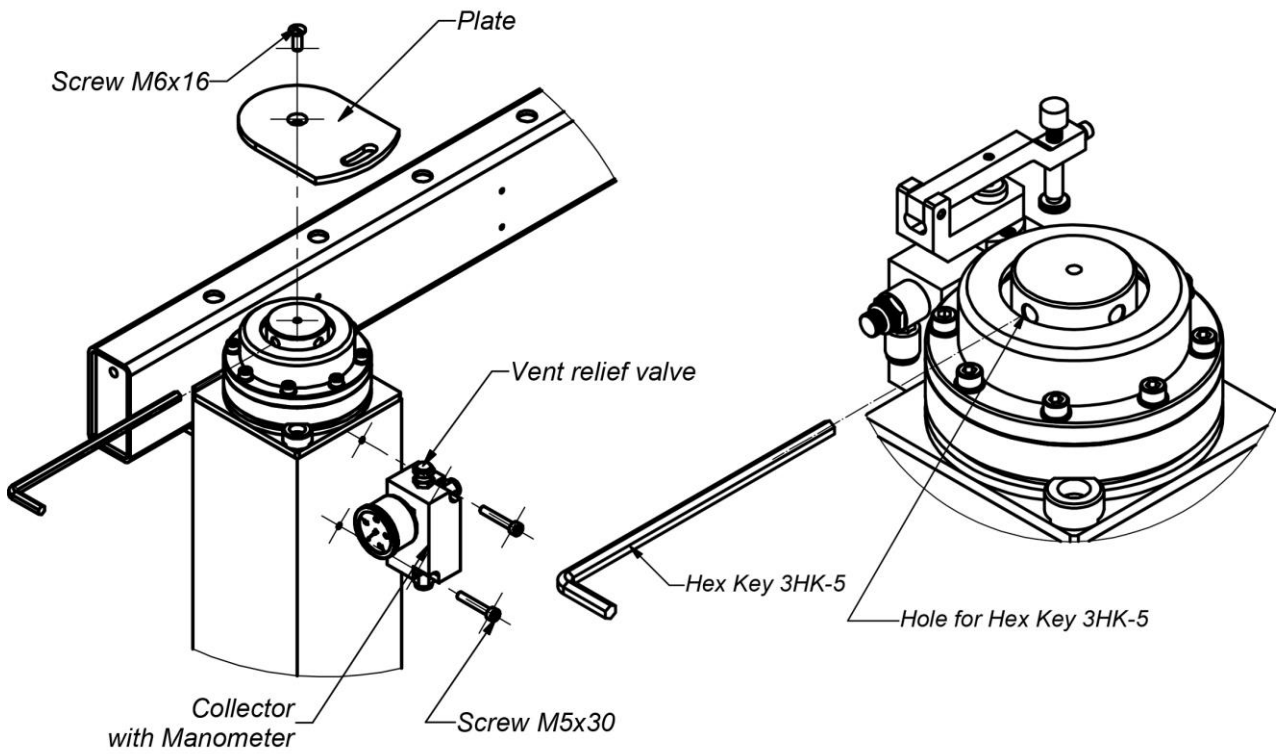
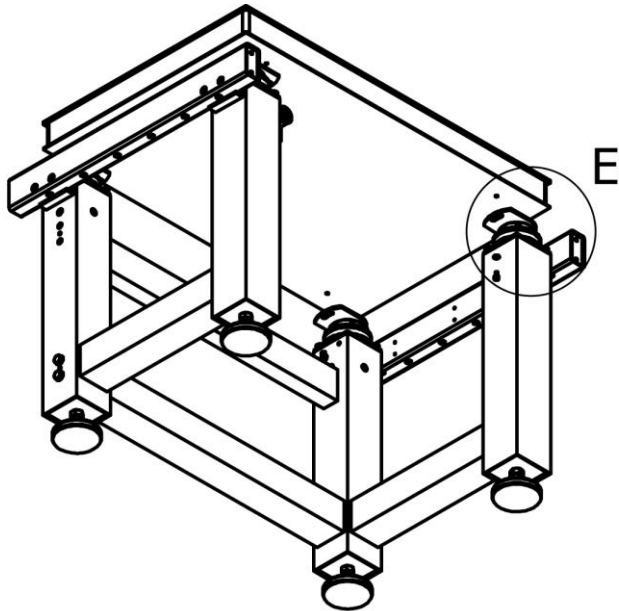

Fig. 8. Fitting the collector and the support plates

2.1.6 Assembly of the table



Place the table accurately on top of the pneumatic supports. If you need to adjust the location of the table, lift the table over the supports.

Attach the optical table to the pneumatic vibration isolation supports by M6x12 screws.

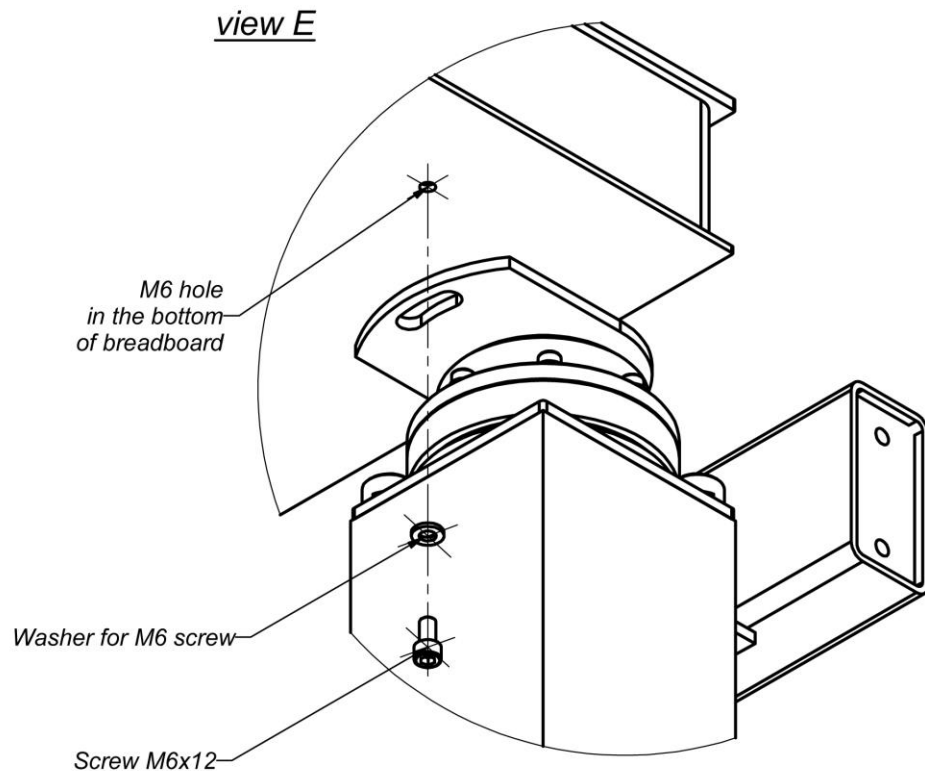

Fig. 9. Assembly of the table

2.2 Preparation of the system for operation and vibration isolation of the table

2.2.1 Assembly of level controls

A level control is shown in fig. 3.

All systems, regardless of the number of pneumatic supports used in them, are provided with 3 level controls that form a triangle. The greater the triangle of a specific optical table is, the more stable is the operation of the system. If 2 or more pneumatic supports are controlled by means of a single level control, then they operate as one large support with the total load-carrying capacity applied to the centre of the shape formed by the pneumatic supports. Groups of pneumatic supports serve as three supports for the system. The aggregate centre of gravity of the optical table and of the useful load present on the table must be within the boundaries of the triangle formed by force centres.

Scheme of connection of level controls is shown in fig. 10.

After placement of the table, level controls must be fastened to the supports as shown in fig. 11 and in fig. 12.

Attach the plate to the leg assembly by M5x10 screws.

Attach the level control to the plate by nut plate (fig.11).

Align the controls horizontally and set the distance from the bracket of the controls to the table at 5 to 6 mm. The control screw of the lever must be set to the bottom position. The needle valve must be turned counter clockwise until tight. Tighten the two mounting screws carefully.

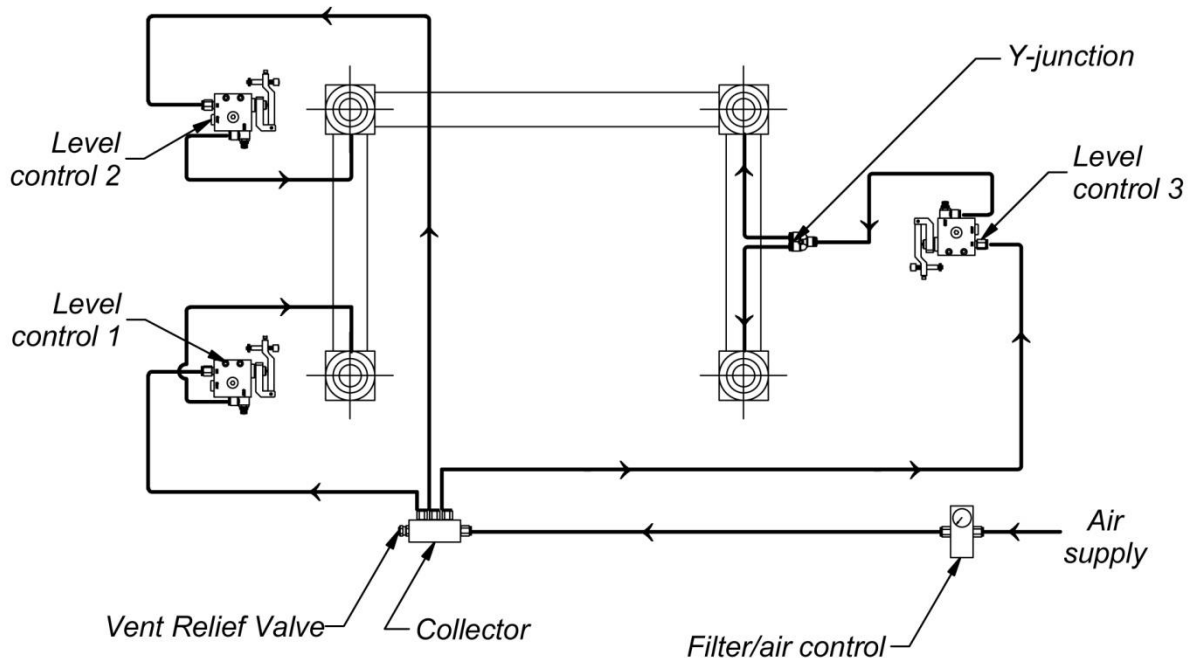

Fig.10. Scheme of connection of level controls

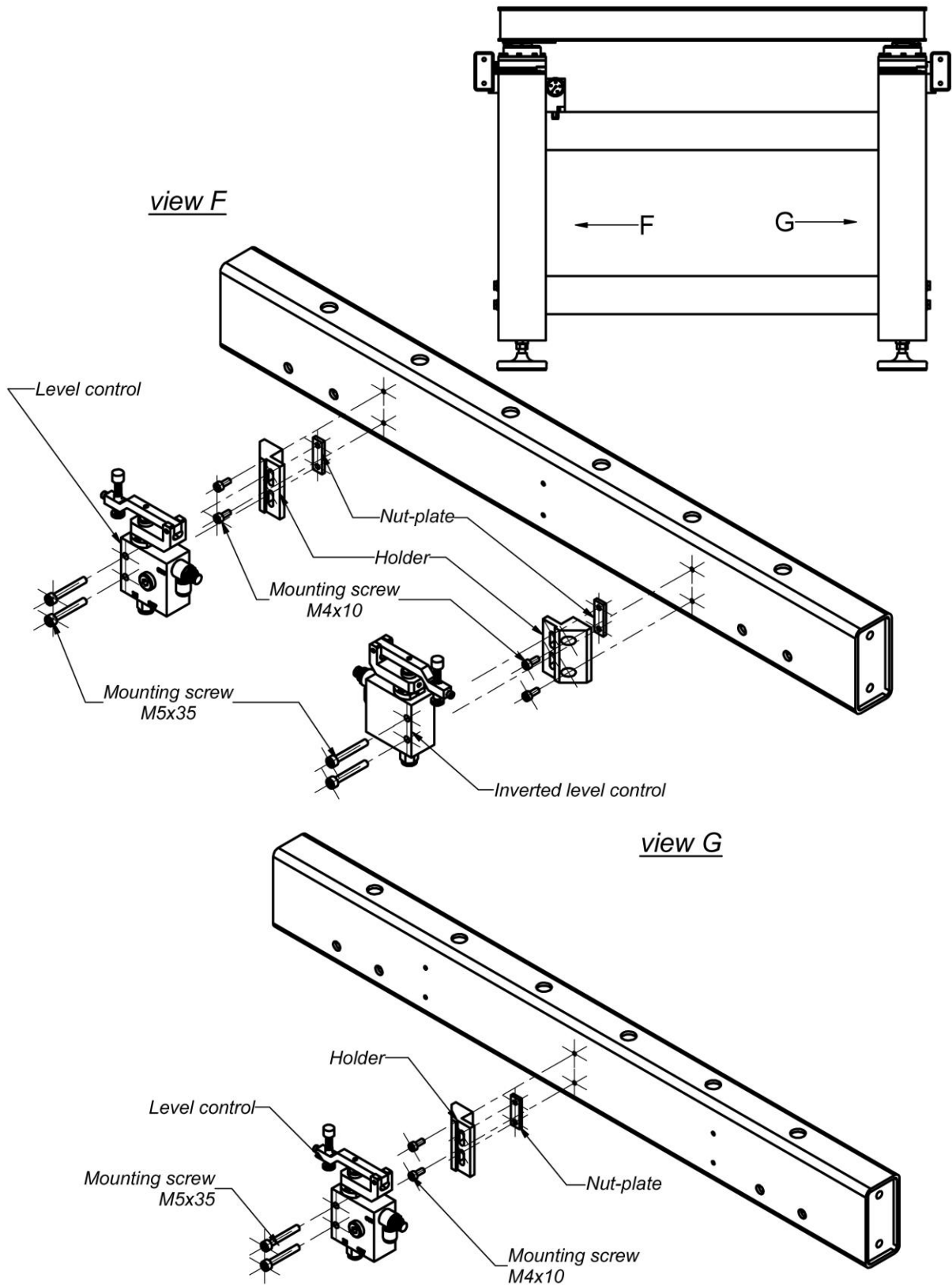

Fig. 11. Installation of level control

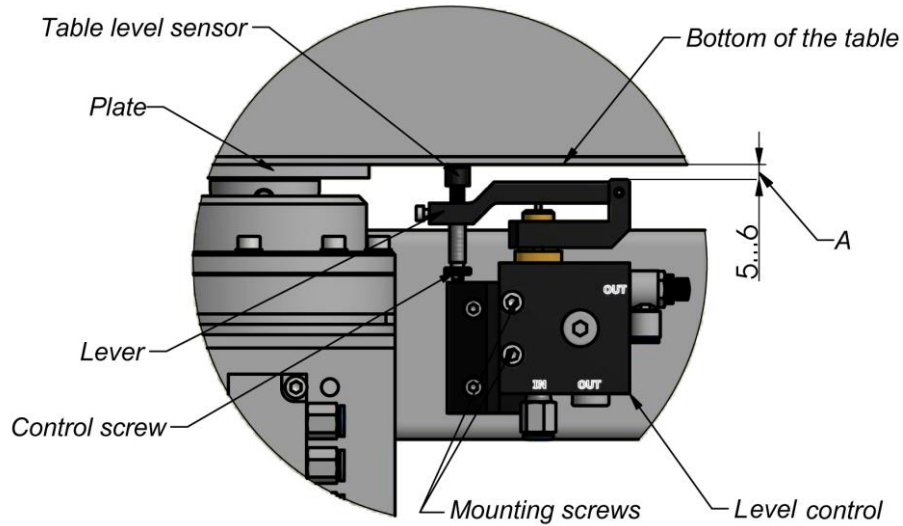

Fig.12. Installation of level control

After placement of the three controls the system must look as shown in fig. 13.

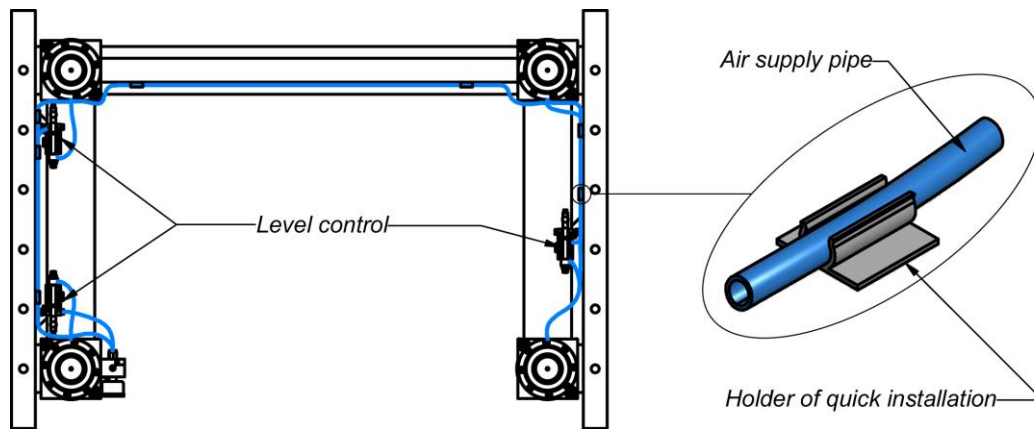

Fig. 13. Vibration isolation system

2.2.2 Connection of air supply pipes

Connect the air supply pipes as shown in fig. 10 as well as in the pneumatic connections scheme that is supplied together with the system.

Warning

Cut the edges of the pipes using a sharp cutter at a straight angle. It is not advisable to use scissors because deformation of the pipe edges may lead to leaks from the system.



Insert the pipes in the collet fittings until tight. Pull the pipes accurately to make sure that the connection is secure.

The length of the pipes between the fittings must be optimal with a small extra length.

Place the tubes along the braces system and secure them with holders of quick installation (fig. 13)

Connect the air supply and set the pressure control based on the computation of its value carried out in advance according to the formula provided in section 1.3.

Attention



The pressure in the system may not exceed 6 bar.

Check all accessible connections for possible leaks. Eliminate any leaks established prior to starting further operation.

If the table does not start to float in a few minutes, increase the air pressure, check whether the needle valve is open and try to adjust the position of the control lever by turning the control screw clockwise.

Note

If the table starts oscillating after emerging, decrease the air pressure in the system and adjust the needle valves by turning them clockwise.

2.2.3 Setting of level controls

When the system is completely floating, check the distance between the plate and the support (see fig. 14). Dimension A must be (7 ± 1.5) mm. Set height A of every control by means of the control screws. When all controls are set, check all three dimensions A once again and adjust them, if needed.

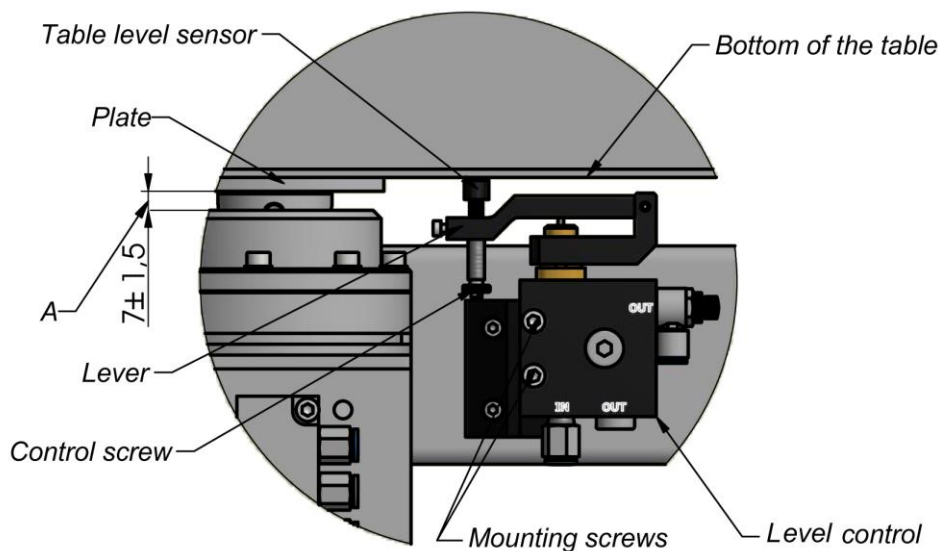

Fig.14. Installation of level control



Make sure that the table is floating freely on the supports. Move the table accurately from side to side by approximately 3 mm. Perform the same operation by moving the table up and down by the same distance. The moving of the table must be unimpeded and must not produce any noises.

Press each of the angles of the table one after another for approximately 3 mm and then release the pressure. The table must return to the original position in approximately 3 to 4 seconds. Adjust if necessary by means of the needle valves and pressure in the system.

3. Management of the system

3.1 Main principles

After completing the assembly of the system and once the table has emerged, minor changes may be introduced based on individual requirements for the system. These adjustments include parameters such as air pressure in the system, position of the level control lever, and setting of the needle valve.

Warning

After the table has emerged, the space between the table and the support may become a zone of danger.

Any object present in this zone may be squeezed in the case of changes in the load on the table or in the pressure, which can result in injuries.

3.2 Adjustment of parameters of the system

If a load has a high weight centre, the table may start to oscillate. In this case, you need to reduce the pressure in the system and close the needle valve. This will improve the stability of the table. The empirical rule to determine the height of the weight centre is shown in fig. 15. The system can be in three different modes – *stable*, *may be stable* and *unstable*, depending on the position of the weight centre. If the overall weight centre is outside of *stable* and *may be stable* areas, the system will lack stability.

3.3 Maintenance

If operated correctly, the pneumatic vibration isolation system needs minimum maintenance. As a rule, the maintenance includes the assurance of the cleanliness of the air supplied, i.e. replacement of the filter and removal of any water.

3.3.1 Cleaning

The table and other parts of the system may be cleaned using a non-abrasive liquid detergent.

3.3.2 Air quality

Oil, water or impurities contained in the air entering the system may clog level controls and worsen the operation of the system. Use of air treatment filters is obligatory. Please refer to section 1.3.

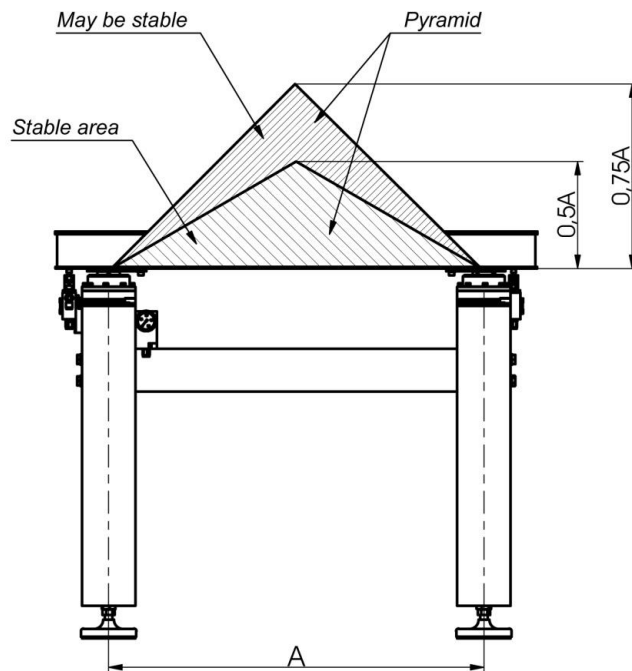
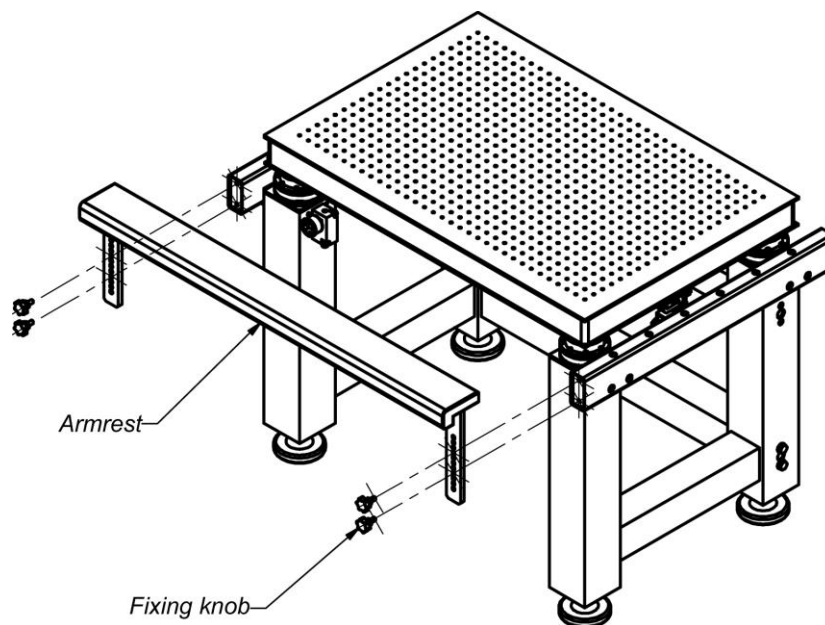

Fig. 15. Empirical rule for the determination of the height of the weight centre

4. Installation of Optional Products

4.1. Armrest

Assembly of the armrest is shown in fig. 16.



Puc. 16. Installation of armrest



Manufacturer of Opto-Mechanical equipment for research, industry and education

P.O. Box 377
03012 Vilnius, Lithuania
Phone: +370-5-2651474
Fax: +370-5-2651483
E-mail: sales@standa.lt
<http://www.standa.lt>