

Motorized Rotation Stages

8MR190-2



- 360 degrees rotation graduated in 1°
- 50.8 mm (2 inch) aperture
- Resolution 4.5 arcsec in 1/8 step
- Zero backlash
- High stability
- Home/zero position limit switch
- Mounting modifications available on request

SPECIFICATIONS

Rotation range	360°
Resolution in full step*	0.6 arcmin (0.01°)
Max.rotation speed*	8 turn/min
Backlash	0 μm
Wobble	0.5 arcmin
Eccentricity	10 μm
Load capacity	
Horizontal	10 kg
Radial	2 kg
Torque	1 Nm
Weight	
8MR190-2	0.65 kg

*Test condition:
 • STANDA controllers;
 • Power supply - 36V.

We are able to equip our stage with any your provided motors

Available INCH version
8MR190E-2

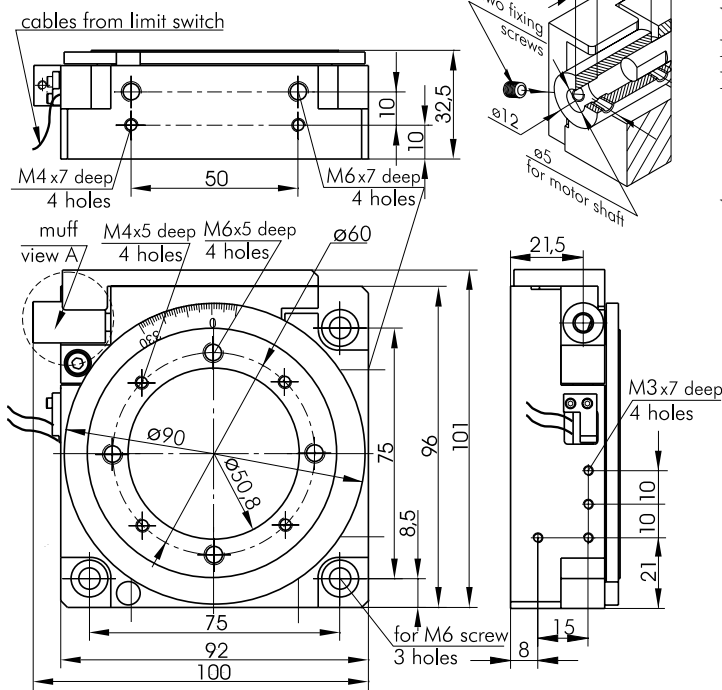

Three steps of connection motor to rotation stage

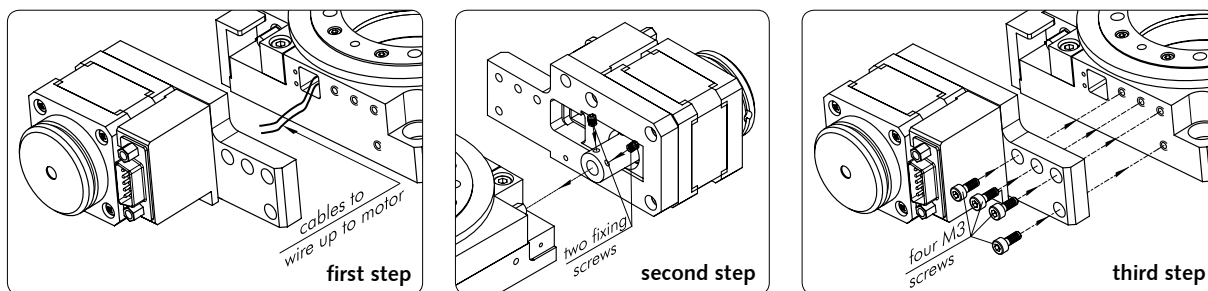

ORDERING INFORMATION

- 8MR190-2** - Rotation stage **8MR190-2** without motor
- 8MR190-2-4247** - Rotation stage **8MR190-2** with stepper motor **4247** (1.2A, 200 steps)
- 8MR190-2-4233** - Rotation stage **8MR190-2** with stepper motor **4233** (0.4A, 200 steps)
- 8MR190-2-28** - Rotation stage **8MR190-2** with stepper motor **28** (0.67A, 200 steps)
- 8MR190-2-ZSS43** - Rotation stage **8MR190-2** with stepper motor **ZSS43** (0.6A, 200 steps)
- 8MR190-2-SM** - Rotation stage **8MR190-2** with **SM system** (more info on the next page)

8MR190-2



http://www.standa.it

e-mail: sales@standa.it

Phone: +370-5-2651474 Fax: +370-5-2651483

standa

Optical Tables	1
Brackets & Rails	2
Base Mounts & Accessories	3
Optical Mounts	4
Optical Positioners	5
Base Positioners	6
Translation & Rotation Stages	7
Motorised Positioners & Controllers	8
Fine Adjustment Screws	9
Opto-Mechanics & Sets	10
Light Test & Measurement Instruments	11