

Technische Zeichnung

Produkt: 1TS

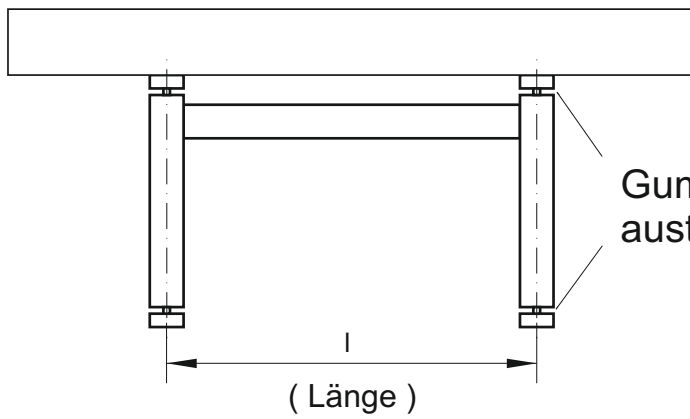

Gummiauflagen /
austauschbar gegen Schwingenisolatoren

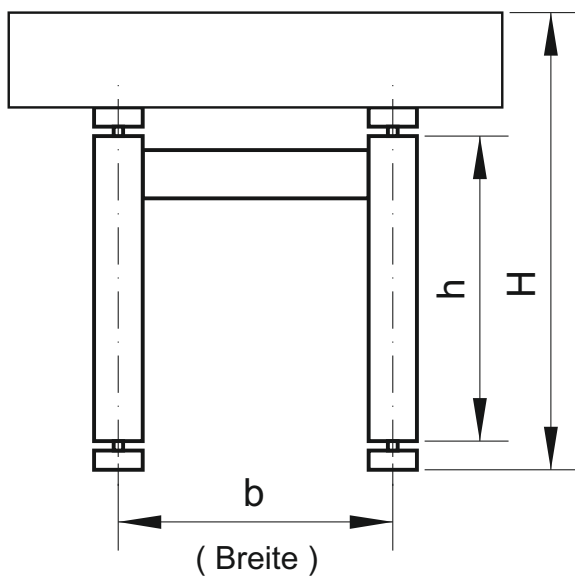

$h = 500 / 600\text{mm} \text{ (-05/-06)}$
 $H = 820-870 / 920-970\text{mm} \text{ (-05/-06)}$